

Amana[®]

Side-by-Side
Refrigerator
Use and Care Guide



CONSUMER INFORMATION LINE
TOLL FREE
1-800-843-0304

Amana
A **Raytheon** Company

Contents

Installation

- Electrical Requirements/Safety Precautions _____ 2
- Model Identification _____ 3

Refrigerator/Freezer Feature Diagrams

- 27 cu. ft. Model, Ice 'N Water Dispenser _____ 4
- 22 cu. ft. Model, without Dispenser _____ 5

Setting Controls

- Free-O'-Frost System _____ 6
- Temp-Assure™ Thermostatic Control _____ 6
- Refrigerator and Freezer Controls _____ 6

Installing and Using Specific Features

Refrigerator

- Dairy Storage _____ 14
- Butter Dish _____ 15
- Food Storage Containers _____ 15
- Beverage Chiller _____ 15
- Adjustable Door Buckets _____ 17
- Door Shelves _____ 18
- Huggers _____ 18
- Adjustable Cantilever Shelves _____ 18
- Utility Rack _____ 19
- Egg Storage _____ 19
- Deli Fresh Chiller _____ 20
- Crispers _____ 21

Freezer

- Removable Door Dike _____ 22
- Door Shelves _____ 22
- Adjustable Door Buckets _____ 23
- Tall Package Retainer _____ 23
- Retainer Bar _____ 23
- Adjustable Compartment Shelves _____ 24
- Glide-Out Wire Basket _____ 24
- Ice Service Rack _____ 24
- Ice 'N Water Dispenser** _____ 25

Other Features

- Decorator Doors _____ 28

Care and Cleaning

- Adhesives _____ 29
- Exterior and Interior _____ 29
- Door Gaskets _____ 29
- Condenser Coil _____ 29
- Odor Removal _____ 29
- Light Bulbs _____ 30

Energy Tips

Vacation Tips

Non-Use Periods

Normal Operating Sounds

Before Calling For Service

Assure Extended Service Plan

Amana Consumer Information Line

- _____ 22
- _____ 22
- _____ 23
- _____ 23
- _____ 23
- _____ 24
- _____ 24
- _____ 24
- _____ 25
- _____ 28
- _____ 29
- _____ 29
- _____ 29
- _____ 29
- _____ 29
- _____ 30
- _____ 32
- _____ 32
- _____ 32
- _____ 33
- _____ 34
- _____ 37
- _____ 37

Electrical Requirements and Safety Precautions



RECOGNIZE THIS SYMBOL AS A SAFETY PRECAUTION



WARNING

Electrical Grounding Instructions

This appliance is equipped with a three-prong (grounding) plug for your protection against possible shock hazards. In locations with two-prong wall receptacles, customers have the personal responsibility and obligation to contact a qualified electrician to replace two-prong wall receptacles with properly grounded three-prong wall receptacles, in accordance with the National Electrical Code.

Unit is designed to operate on a separate 103-126 volt, 15 amp, 60 cycle line.

DO NOT, UNDER ANY CIRCUMSTANCES, CUT OR REMOVE ROUND GROUNDING PRONG FROM PLUG. THE UNIT MUST BE GROUNDED AT ALL TIMES. DO NOT REMOVE WARNING TAG FROM POWER CORD.



WARNING

DO NOT USE A TWO-PRONG ADAPTER. DO NOT USE AN EXTENSION CORD.

ELECTRICAL PLUG

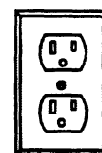

ELECTRICAL RECEPTACLE

ROUND GROUNDING PRONG

Amana Side-by-Side Freezer Refrigerator

Thank you for buying an Amana refrigerator. Your satisfaction with this product is very important to us.

Please read this Use and Care Guide thoroughly. It will help you understand how the refrigerator operates and how to get the most benefit from the selected features.

Complete the Registration Card and return it promptly to Amana's Product Registration Department. If the registration card is missing, call 1-800-843-0304.

If it seems something is operating incorrectly, please read the section **Before Calling For Service**, pages 34 through 36. For unanswered questions, please call Amana's Consumer Information Line at 1-800-843-0304, weekdays during normal business hours, Central Time.

Whenever calling or writing Amana, have the following information available. Take a moment now to locate the nameplate, inside the front upper left corner of the refrigerator compartment, and copy the necessary information into the spaces below.

Serial Number _____

Model Number _____

Manufacturing Number _____

Please also record:

Date of Purchase _____

Name of Selling Dealer _____

Dealer Address _____

Keep a copy of the sales receipt for future reference, in case warranty service is required.

Amana offers a complete line of kitchen and laundry appliances, including freezers, ranges, cooktops, wall ovens, microwave ovens, dishwashers, washers and dryers. High-efficiency gas furnaces, central air conditioners and room air conditioners are also available. Choose Amana every time!

Enjoy your new refrigerator!

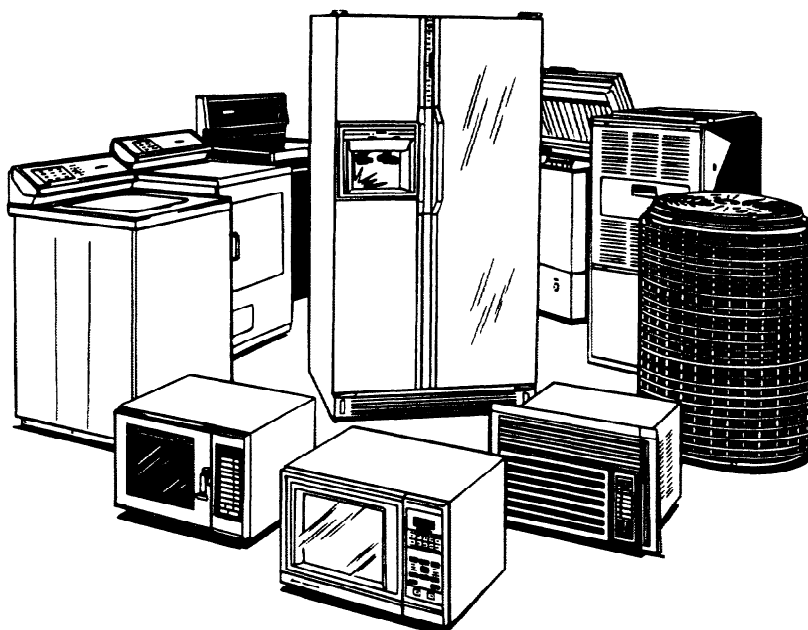

Refrigerator Features

27 cu. ft. Model, with Ice 'N Water Dispenser

IMPORTANT

Features vary from model to model. Your refrigerator may not have all features shown.

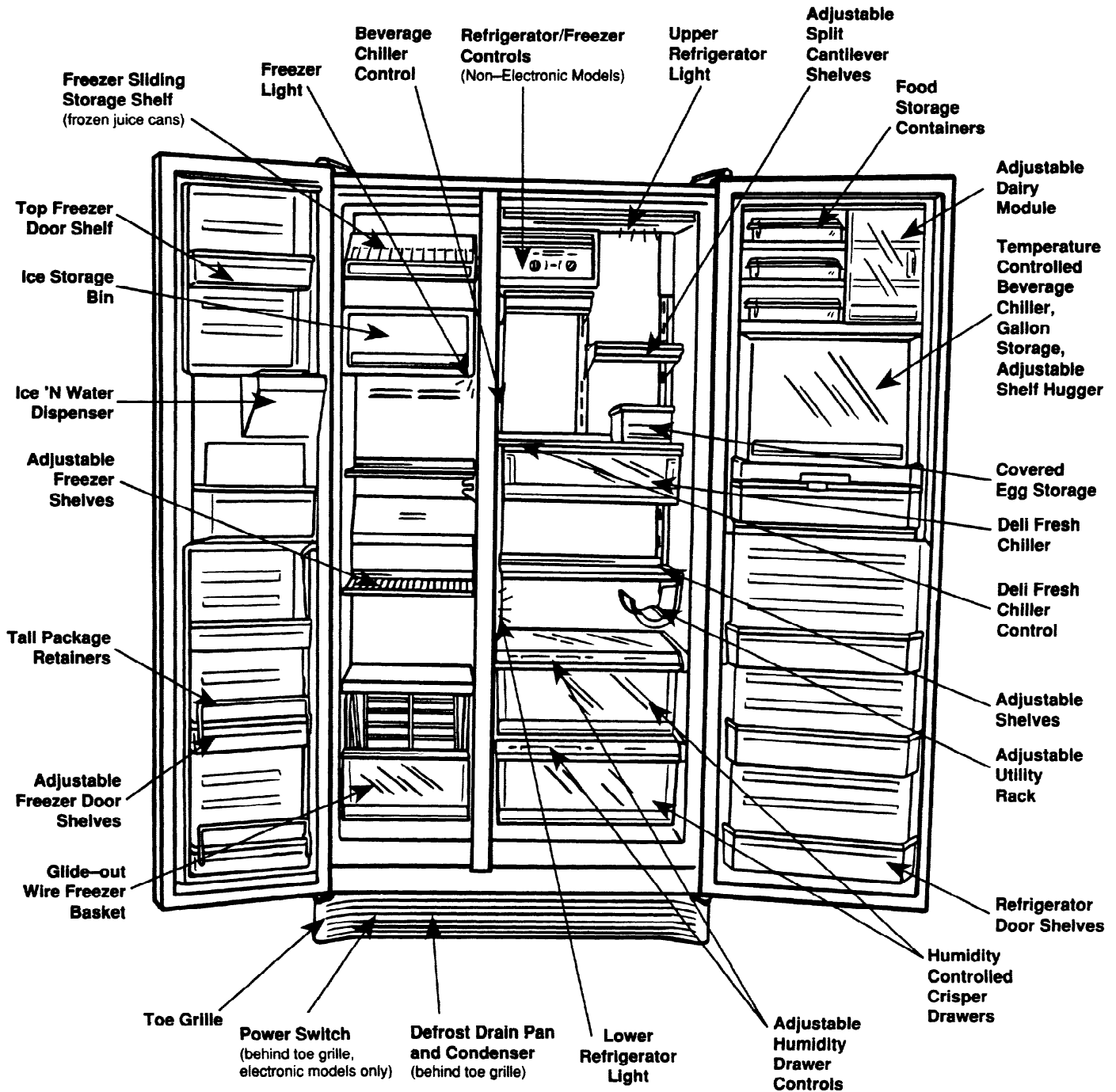

Refrigerator Features

22 cu. ft. Model, without Dispenser

IMPORTANT

Features vary from model to model. Your refrigerator may not have all features shown.

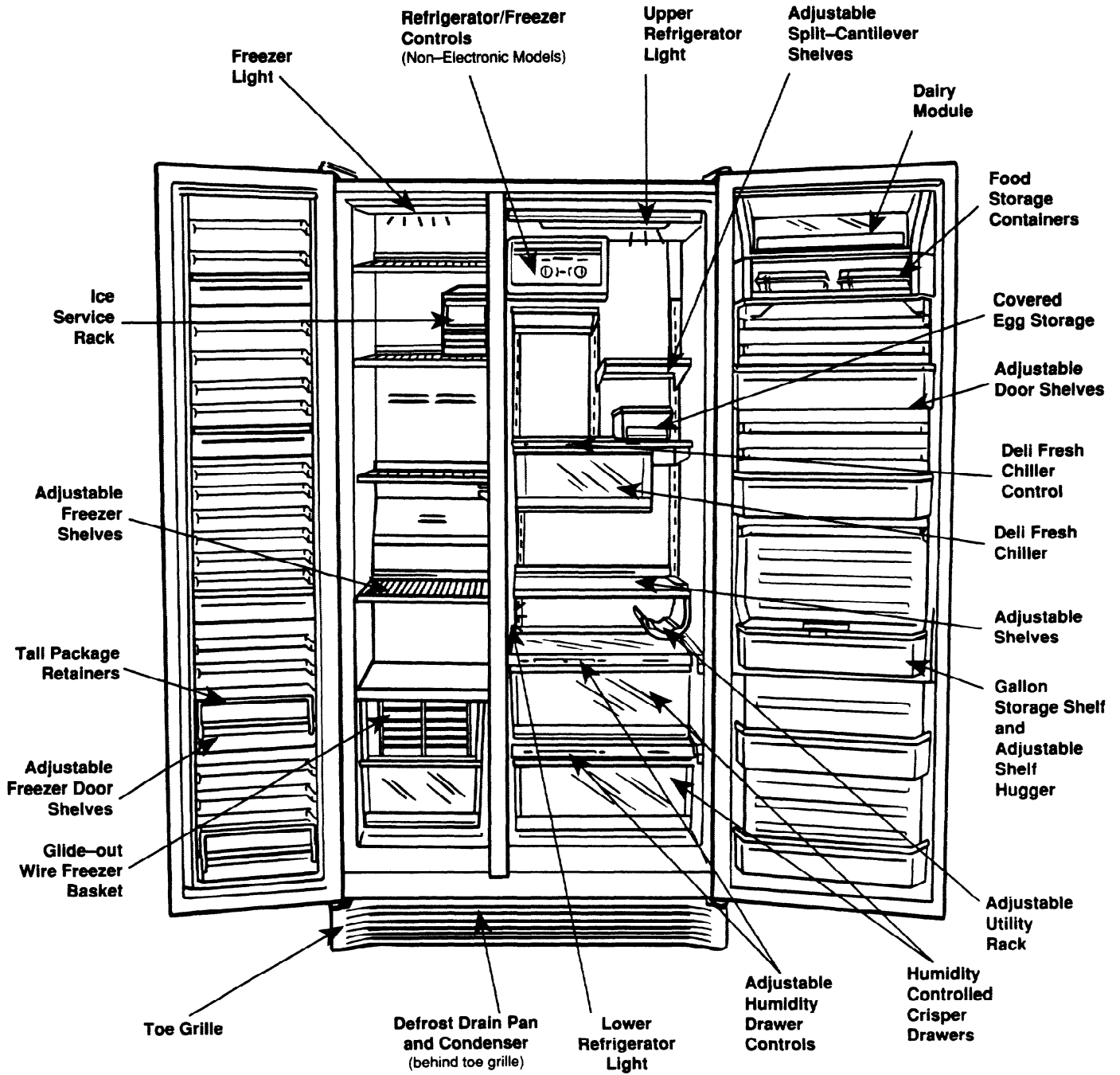

Setting the Controls

Controls vary from model to model. Your refrigerator may not have all controls shown.

Free-O'-Frost™ System

The Amana Frost-Magnet® evaporator coil provides completely automatic frost-free operation of refrigerator and freezer compartments. Under normal operating conditions, manual defrosting is not necessary. Proper placement of refrigerator is necessary for adequate air circulation and operation.

IMPORTANT

20 cu. ft. models **require** clearance in front of toe grille at bottom of refrigerator. The same grille is used for both air intake and exhaust, allowing unit to be enclosed (built-in) at top, back and sides.

19, 22, 25, 27 cu. ft. models **require** clearance in front of toe grille and a one-inch clearance at back and top of refrigerator for proper air exhaust. **Leave factory-installed spacers in place.**

Temp-Assure™ Thermostatic Control

On upper rear wall inside refrigerator compartment are the Temp-Assure™ system controls. Operating independently of freezer control, a hidden thermostatic sensor constantly measures refrigerator air temperature. If temperature rises as little as 1-1/2 degrees F (.8 degrees C) from set point, cold air is automatically added to refrigerator compartment. See Figure 1.

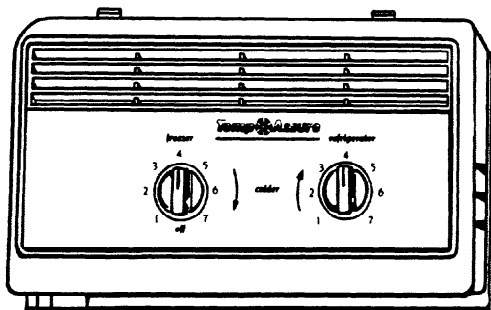

Figure 1

Refrigerator and Freezer Controls

When freezer control is **OFF**, neither refrigerator nor freezer compartments cool. Allow 24 hours after installation for refrigerator and freezer temperatures to stabilize.

- Locate refrigerator control inside compartment on upper rear wall. Set control to "4" and adjust as desired after 24 hours. "1" is warmest setting; "7" is coldest setting. See Figure 2.

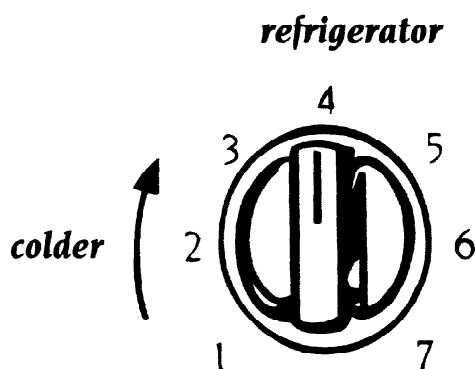

Figure 2

- Locate freezer control inside compartment at front of upper left corner. Set control to "4" and adjust as desired after 24 hours. "1" is warmest setting; "7" is coldest setting. See Figure 3.

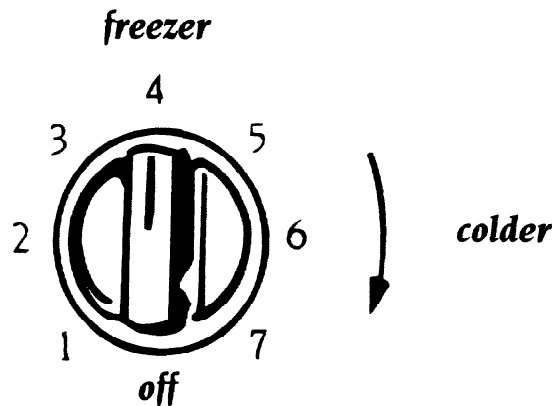

Figure 3

Setting the Controls (continued)

To adjust temperatures more precisely, use a household thermometer (usually available at hardware stores) with a temperature range between -5°F and $+50^{\circ}\text{F}$ (-20.5°C and $+10^{\circ}\text{C}$).

- a. In freezer compartment, place thermometer snugly between packages of frozen food for 5 to 8 hours. See Figure 4. If temperature is not between 0°F and $+2^{\circ}\text{F}$ (-18°C and -17°C), adjust control one number at a time and check again after 5 to 8 hours.

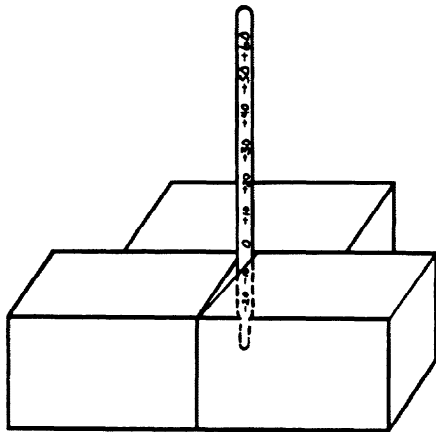

Figure 4

- b. In refrigerator, place a glass of water holding thermometer in center of compartment for 5 to 8 hours. See Figure 5. If temperature is not between 38°F and 40°F (3°C to 4°C), adjust control one number at a time and check again after 5 to 8 hours.

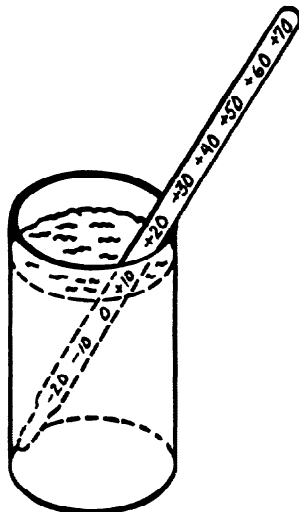

Figure 5

Beverage Chiller Control

Keep beverages up to 5 degrees F (3°C) cooler than the refrigerator compartment by adjusting the amount of freezer air circulated to the beverage chiller. Additional cold air may affect refrigerator compartment temperature.

- a. Locate control dial on left front wall of interior refrigerator compartment. See Figure 6.

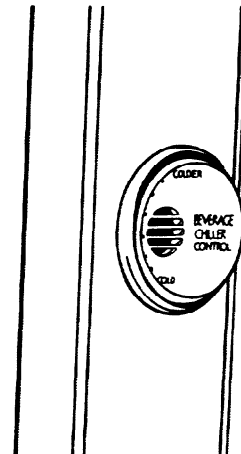

Figure 6

- b. Turn dial clockwise for colder temperatures; turn dial counter-clockwise for warmer temperatures.
- c. Locate air inlet, allowing freezer air to pass to beverage chiller, on interior wall of refrigerator door. See Figure 7.

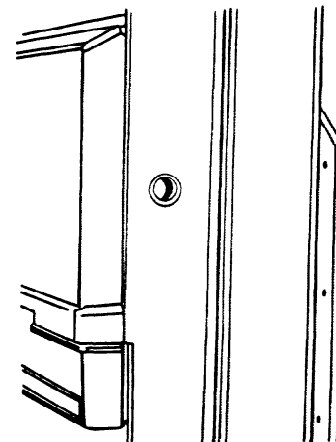

Figure 7

- d. Adjust Temp-Assure™ Thermostatic Control after establishing beverage chiller temperature, if necessary, to bring refrigerator compartment temperature within normal operating range of 38°F to 40°F (3°C to 4°C).

Setting the Controls (continued)

Touchmatic™ Electronic Controls

(27 cu. ft. models only)

The Amana Touchmatic™ Electronic Control Center is a simple-to-operate indicator panel located on the outside of the refrigerator door above the handle. The Control Center provides alerts for open doors, high temperatures in freezer/refrigerator compartments, reminders for cleaning condenser coils, and much more.

Follow basic instructions below for proper operation of the new Amana Touchmatic™ Electronic Refrigerator.

Before you begin . . .

- The power switch is set at factory and must remain **ON**.
- To check position of power switch, remove toe grille from bottom of refrigerator and locate switch at center of cabinet.
- If necessary, set switch to **ON** position and replace toe grille. See Figure 8.

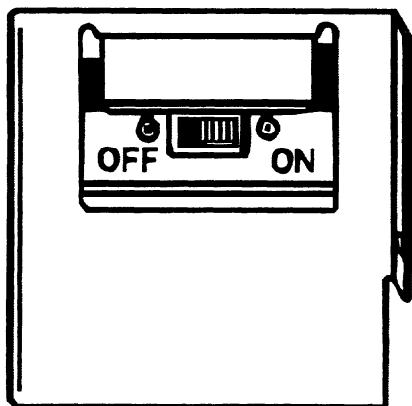

Figure 8

NOTE

When refrigerator is first plugged in, temperature indicator lights will blink. Press **START** pad (*) or **ALARM OFF** pad. See Figure 9.

- Allow 24 hours after installation for refrigerator and freezer temperatures to stabilize.
- Within two (2) hours, if refrigerator and freezer have not been cooled to proper temperature, alarm may sound and **HIGH TEMP** indicator light may flash.
- Deactivate alarm by pressing **ALARM OFF** pad. See Figure 9.



OR



Figure 9

Programming Refrigerator Functions

START Pad

Activate Control Panel by pressing **START** pad (*). Pressing **START** pad turns on temperature indicator lights and allows use of other Control Panel pads. Except for **ALARM OFF**, all other pads remain inactive until **START** pad is pressed. **Once activated, pads remain programmable for at least ten (10) minutes.** See Figure 10.

Setting the Controls (continued)



Figure 10

Optional ENTRY TONE

Whenever a pad is pressed, an optional pre-set 'beep' signal indicates a command has been "read" and accepted.

- a. To *cancel* Optional Entry Tone, press and hold START pad (*) approximately three (3) to five (5) seconds. Three (3) short beeps indicate instructions are accepted.
- b. To *reactivate* Entry Tone, repeat process above.

Setting Temperature Functions

The Amana Touchmatic™ Electronic Control allows precise setting of refrigerator and freezer compartment temperatures, independent of each other, without opening doors. **Optimum refrigerator food storage temperature range is 38° F to 40° F (3° C to 4° C).** Nine temperature levels — 1 (warmest) to 9 (coldest) — are available for each compartment. Temperature levels are pre-set at number 5. Indicator lights are ON when temperature levels are adjusted, to identify compartment of change (freezer or refrigerator) and to show current setting. *Allow 24 hours after installation for refrigerator and freezer temperatures to stabilize.*

- a. To set or change refrigerator temperature, press START pad (*); press REFRIG TEMP; press WARMER or COLDER to raise or lower temperature setting *one* level at a time. Holding down WARMER or COLDER pads raises or lowers temperature *more than one* level at a time. See Figure 11.

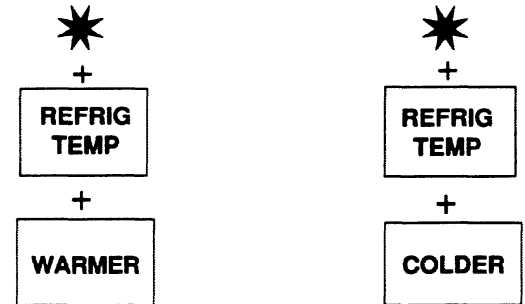

Figure 11

- b. To set or change freezer temperature, press START pad (*); press FREEZER TEMP; press WARMER or COLDER to raise or lower temperature setting *one* level at a time. Holding down WARMER or COLDER pads raises or lowers temperature *more than one* level at a time. See Figure 12.

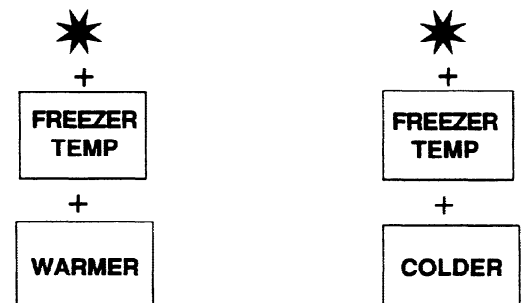

Figure 12

Setting the Controls (continued)

- c. Load refrigerator and freezer food compartments.
- d. Check food temperature (refer to page 6) and adjust compartment controls, one number at a time, as needed.
- e. To cancel Temperature Display lights, press START pad (*); press DISPLAY OFF. See Figure 13.

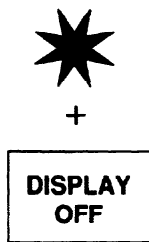

Figure 13

- f. To reactivate Temperature Display lights, press any of the top five (5) pads. See Figure 14.

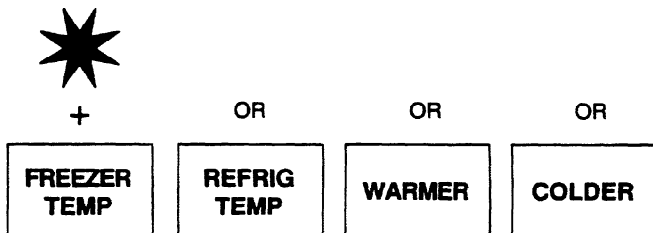

Figure 14

VACATION Mode

Before leaving for extended periods of time, set energy-saving Vacation Mode to preserve food in refrigerator by defrosting less often.

- a. To set VACATION mode, press START pad (*); press VACATION pad. Indicator light will glow. See Figure 15.



Figure 15

- b. To cancel VACATION mode, press START pad (*); press VACATION pad again OR open either freezer or refrigerator door. See Figure 16.

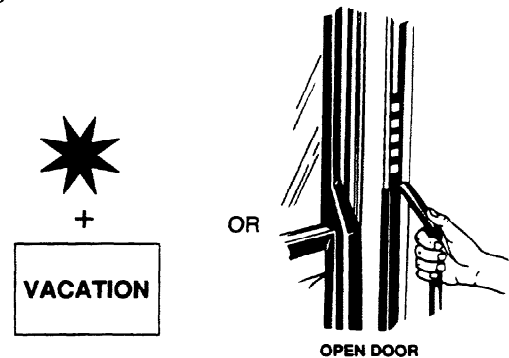

Figure 16

CAUTION
 To avoid risk of property damage during periods of non-use, see pages 28 and 32 for important ice maker instructions.

Setting the Controls (continued)

MAX COOL Mode

Reduces refrigerator temperature to coldest setting for 10 hours, for use when adding a large amount of warm food to compartment or if colder chilled drinks are preferred. After 10 hours, refrigerator temperature returns to previous setting.

- a. To set MAX COOL mode, press START (*) pad; press MAX COOL pad. Indicator light will glow. See Figure 17.

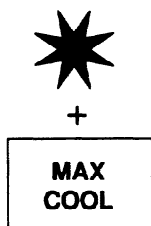

Figure 17

- b. To cancel MAX COOL mode before 10-hour automatic re-set, press START (*) pad; press MAX COOL pad again. See Figure 18.

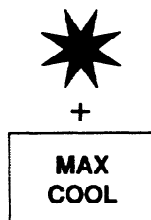

Figure 18

FAST FREEZE Mode

Reduces freezer temperature to coldest setting for 24 hours, for quickly freezing large amounts of food. After 24 hours, freezer temperature automatically returns to previous setting.

- a. To set FAST FREEZE mode, press START pad (*); press FAST FRZ pad. Indicator light will glow. See Figure 19.

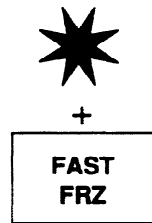

Figure 19

- b. To cancel FAST FREEZE mode before 24-hour automatic re-set, press START pad (*); press FAST FRZ pad again. See Figure 20.

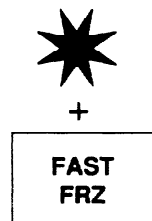

Figure 20

Setting the Controls (continued)

ALERT Signals

The Amana Touchmatic™ refrigerator includes specially designed audio and visual signals not available with conventional refrigerators, which quickly call attention to potentially harmful conditions.

DOOR OPEN

Alarm

Whenever either refrigerator or freezer door is open, indicator light glows. If either door is open for three (3) minutes, glowing indicator light blinks and alarm sounds.

- a. To deactivate Door Open Audio Alarm, press ALARM OFF or close the door(s). See Figure 21.

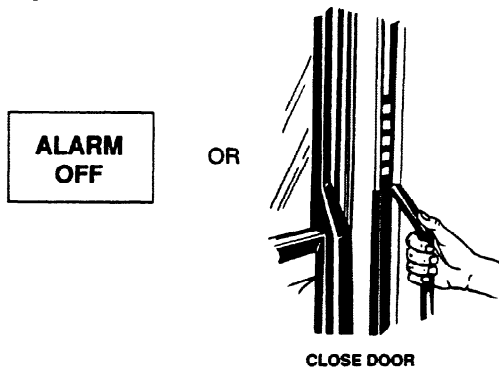

Figure 21

- b. To reactivate Door Open Audio Alarm, press START (*) pad; hold ALARM OFF pad for 3 to 5 seconds until three short beeps sound, indicating instructions are registered. See Figure 22.



Figure 22

- c. To cancel Door Open Audio Alarm indefinitely, press START (*) pad; hold ALARM OFF pad for 3 to 5 seconds until three short beeps sound, indicating instructions are registered. See Figure 23.



Figure 23

HIGH TEMPERATURE

Alarm

An audio alarm sounds and the appropriate FREEZER TEMP and/or REFRIGERATOR TEMP indicator light glows if freezer and/or refrigerator temperature is excessively warm for extended period of time. A blinking light signals affected compartment. Check for possible food spoilage.

- a. To discontinue High Temperature Alarm and clear indicator light, press ALARM OFF pad. See Figure 24.



Figure 24

Setting the Controls (continued)

- b. Audio alarm discontinues when proper temperature in freezer and/or refrigerator compartments is regained.
- c. Press ALARM OFF to clear High Temperature indicator light.

THERMISTOR

Alarm

If the refrigerator or freezer thermistor fails, five (5) beeps will sound and the four temperature indicator pads in center of display light in a scrolling sequence.

IMPORTANT

Contact an authorized Amana Servicer **immediately** if **THERMISTOR** alarm sounds and scrolling display is seen.

- a. To deactivate display, press ALARM OFF. See Figure 25.



Figure 25

IMPORTANT

After **ALARM OFF** pad is pressed, thermistor control retests to ensure condition has been corrected. **Alarm** sounds again if thermistor is not operating properly.

CLEAN CONDENSER COIL

Alarm

Every three (3) months, indicator light glows as a reminder to clean condenser coil for more efficient operation. For information on cleaning the condenser coil, refer to page 29.

- a. Light automatically cancels in 72 hours.
- b. NO audio alarm sounds.
- c. To cancel Clean Condenser Alarm before 72-hour automatic period, press ALARM OFF pad. See Figure 26.



Figure 26

Installing and Using Specific Features

Refrigerator Features

Features vary from model to model. Your refrigerator may not have all features shown.

Starting with the refrigerator door, features are outlined from top to bottom of unit, and move from the door into the refrigerator compartment.

Dairy Storage

An adjustable dairy module offers several storage options.

- a. The flexible sliding door can be removed for hand-washing by grasping bottom of door. Gently lift up and pull out of door track. See Figure 27.

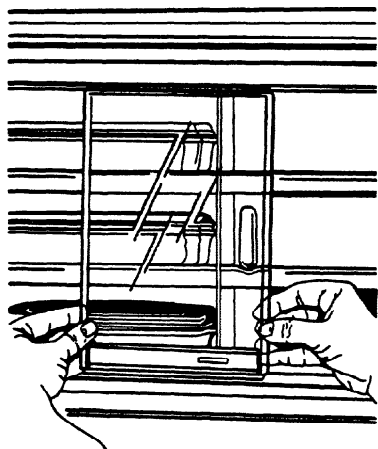

Figure 27

- b. Within the dairy module, many package sizes can be stored by moving shelves. Lift front edge of shelf and pull out at an angle to remove. See Figure 28.

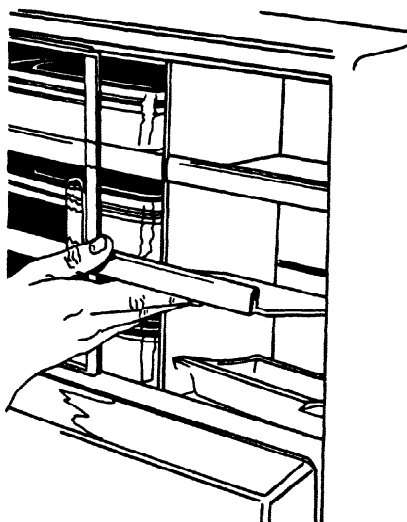

Figure 28

- c. Trim on front of dairy module shelf slides to left or right for removal. See Figure 29.

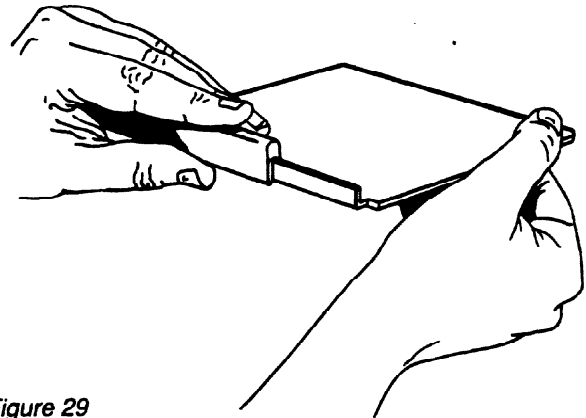

Figure 29

- d. Use front trim as a tall package retainer by sliding trim into compartment without shelf. See Figures 30, 31 and 32.

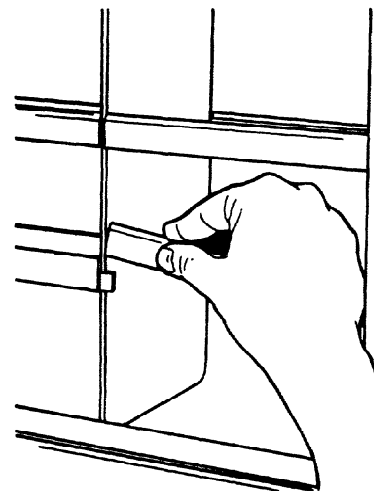

Figure 30



Figure 31

Installing and Using Specific Features (continued)



Figure 32

- e. Storage compartment on some models has removable, hand-washable tilt-up door. See Figure 33.

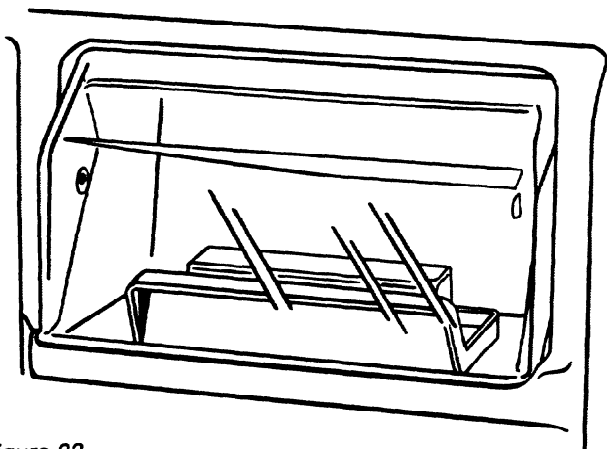

Figure 33

Butter Dish

Microwave-safe and top-rack dishwasher-safe butter dish provides convenient tablespoon portions and may be taken to the table. See Figure 34.

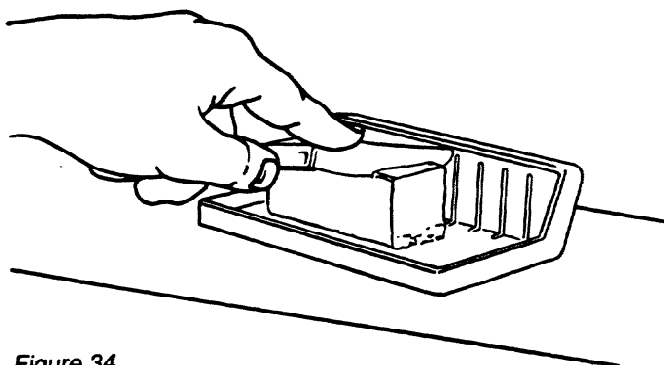

Figure 34

Food Storage Containers

Microwave-safe and top-rack dishwasher-safe sealable food storage containers are stored in a slide-out compartment. Follow manufacturer's recommendations for reheating food and for cleaning. See Figure 35.



Figure 35

Beverage Chiller

A temperature-controlled section, with sliding door, keeps beverages up to 5 degrees F cooler than the refrigerator compartment. See Figure 36.

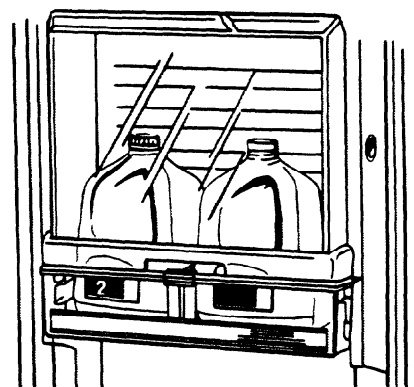

Figure 36

Installing and Using Specific Features (continued)

- a. Open beverage chiller by sliding door upward. Door remains in position until moved again. Door locks in place at highest position. See Figure 37.

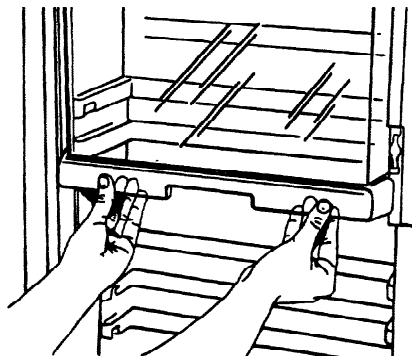

Figure 37

- b. Extra-deep beverage chiller shelf (20, 25 cu. ft. models) allows for storage of large and gallon-size beverage containers and may be removed for cleaning.
- c. Remove all food from shelf and grasp each end of shelf retainer. Pull shelf straight up and out. See Figure 38.

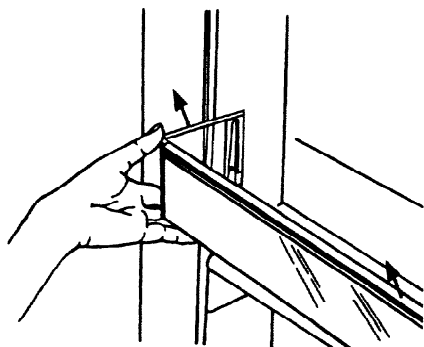

Figure 38

- d. Extra-deep beverage chiller bucket (27 cu. ft. models only) allows for storage of large and gallon-size beverage containers and may be removed for cleaning. See Figure 39.

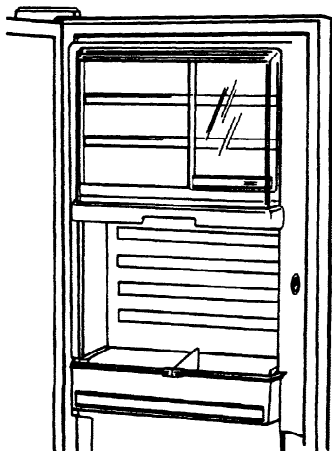

Figure 39

- e. Remove all food from bucket and grasp sides of bucket with thumbs and forefingers of both hands. Push and hold lock tabs toward center of bucket. See Figure 40.

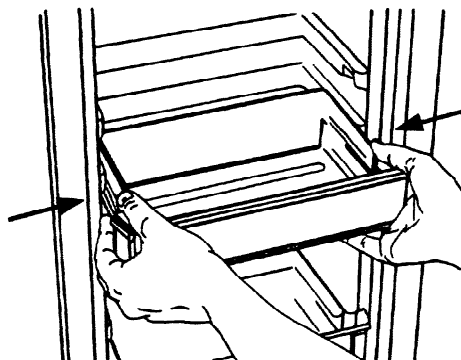

Figure 40

- f. Move bucket by holding lock tabs in and pulling bucket straight out. See Figure 41.

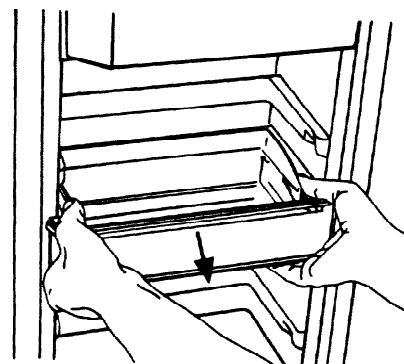

Figure 41

- g. To reinstall, use one hand at each side of bucket. Slide bucket into grooves on door. Push gently with thumbs until tabs snap and lock into place. See Figure 42.

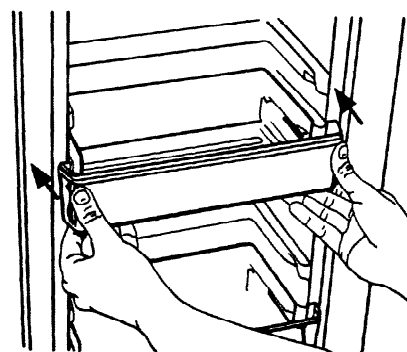

Figure 42

Installing and Using Specific Features (continued)

h. To remove beverage chiller door, remove chiller bucket. Slide door down and out through bottom of door track. See Figure 43.

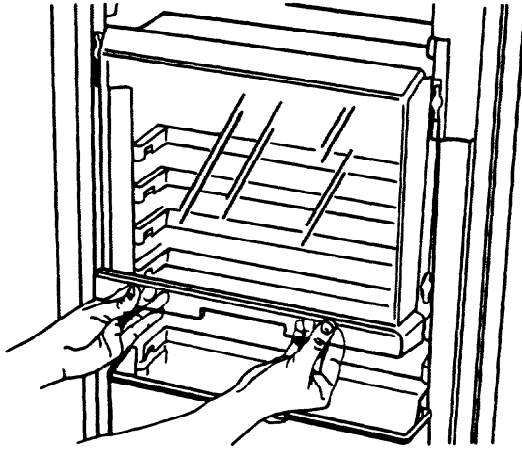

Figure 43

i. Retention glides **must** remain in place to reinstall chiller door. See Figure 44.

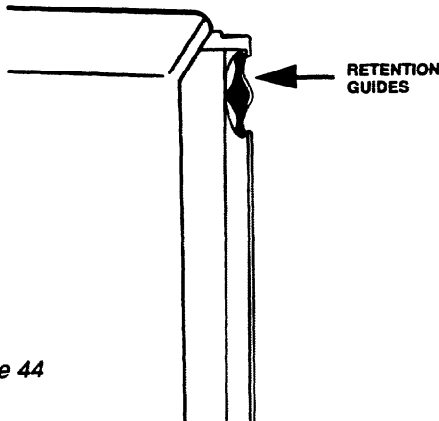

Figure 44

j. Reinstall chiller door by sliding door up through bottom of door track. Replace chiller bucket.

Adjustable Door Buckets

Storage buckets on refrigerator door can be moved up or down as needed.

- a. Remove all food from buckets.
- b. With thumbs and forefingers of both hands, push and hold lock tabs toward center of bucket. See Figure 45.

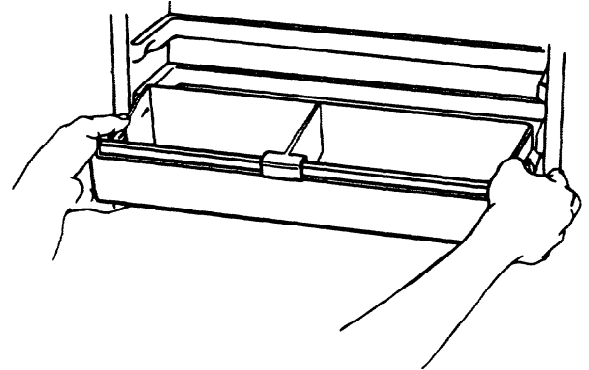

Figure 45

c. Move bucket by holding lock tabs in and pulling bucket straight out. See Figure 46.

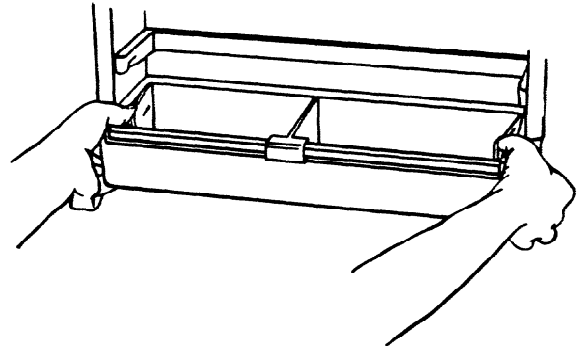

Figure 46

d. To reinstall, use one hand at each side of bucket. Slide bucket into grooves on door. Push gently with thumbs until tabs snap and lock into place. See Figure 47.

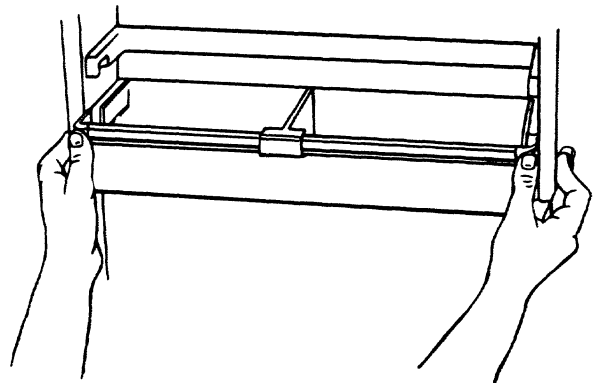

Figure 47

Installing and Using Specific Features (continued)

Door Shelves

Two styles of shelves on refrigerator door can be removed for cleaning.

- a. Remove all food from shelves.
- b. Remove slide-in-style shelf by grasping each side of shelf retainer. Lift shelf straight up and out. See Figure 48.

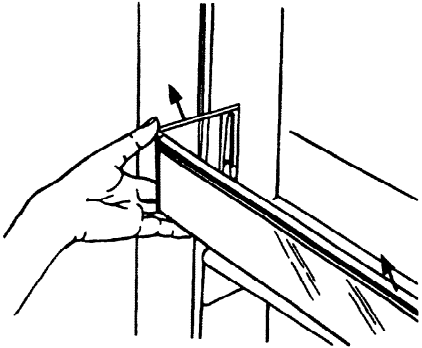

Figure 48

- c. To remove hook-style shelves, gently tap upward underneath both ends. Lift and rotate bottom of shelf outward to release hooks from door slots.
- d. To reinstall, tilt shelf and insert upper hooks into selected slots. Rotate shelf toward door and insert lower hooks into door slots.
- e. Hold shelf against door and tap down gently on both ends until shelf is seated securely. See Figure 49.

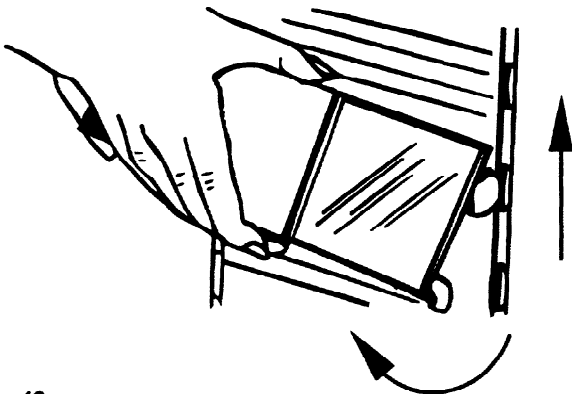

Figure 49

Huggers

Huggers are door shelf dividers used for keeping contents in place.

Hook hugger over front edge of door shelf and slide side to side as needed. See Figure 50.

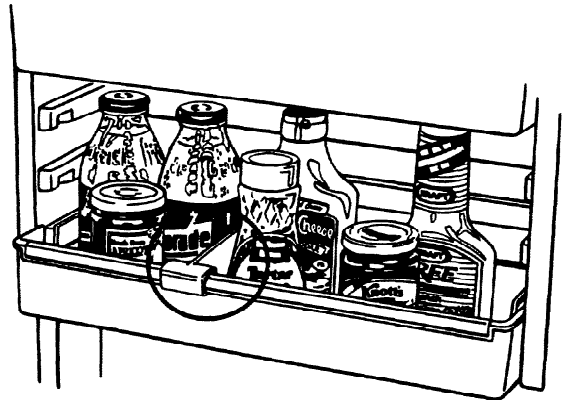

Figure 50

Adjustable Spillsaver™ Cantilever Shelves

Spillsaver™ shelves localize spills and may hold up to ten ounces of spilled liquid. Supported by metal tracks on the rear wall of refrigerator compartment, shelves can be adjusted to best match size of stored items. See Figure 51.

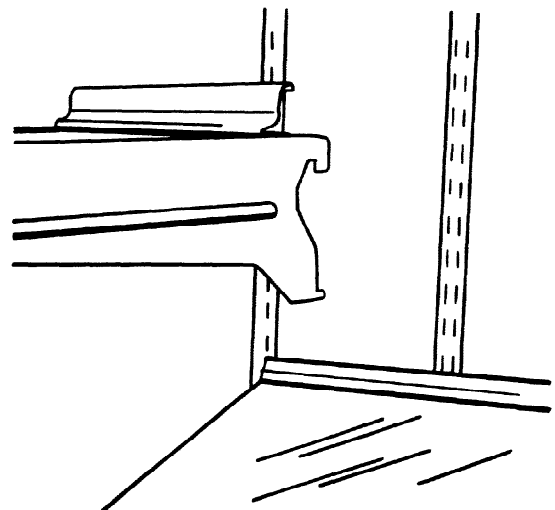

Figure 51

Installing and Using Specific Features (continued)

- a. Remove cantilever shelf by lifting upward at back edge of shelf near metal track to loosen shelf hooks. See Figure 52.

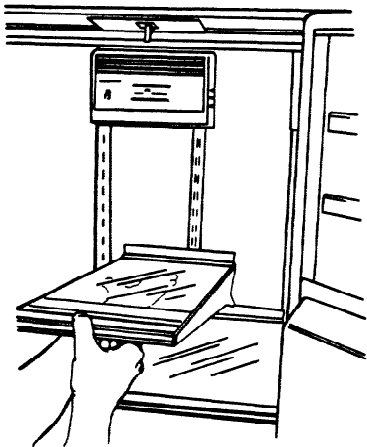

Figure 52

- b. Tilt up on front edge of shelf and pull out. See Figure 53.

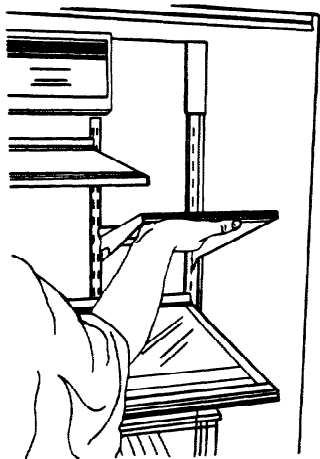

Figure 53

- c. Reinstall shelf by inserting upper rear metal shelf hooks into desired wall slots, as front edge of shelf is tilted up. Gently press down on front edge of shelf until lower hooks are firmly seated in rear wall slots and shelf is level.

CAUTION

Gently apply pressure to front edge of shelf to insure proper installation.

Handle tempered-glass shelves with care. Place on soft surface after removing. Do not expose shelves to rapid temperature changes. Replace shelves immediately if they become chipped or cracked, as sudden breakage could occur.

Utility Rack

For movable, space-saving, under-shelf storage, hang utility rack on the edge of any shelf. Remove rack from shipping location in crisper drawer.

- a. Tabs on flat edge of rack hook over metal frame at the side of any shelf. See Figure 54.
b. Before placing bottle in rack, check that cap is tight.

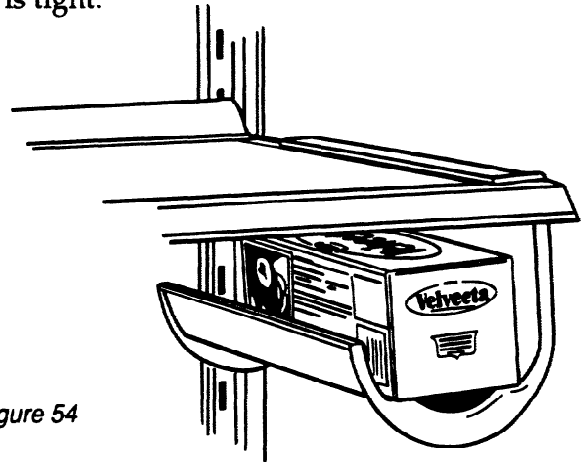

Figure 54

Egg Storage

Store eggs in a take-to-the-counter bucket with removable tray. See Figure 55.

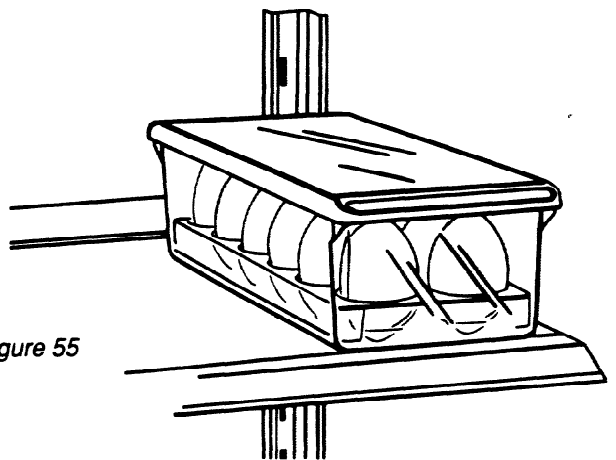

Figure 55

Installing and Using Specific Features (continued)

Deli Fresh Chiller

For fresh, moist fish, poultry or meat, freezer air is circulated in a sleeve around the Deli Fresh Chiller drawer. A front panel control allows temperature adjustment. For flexible storage, Deli Fresh Chiller may be repositioned within refrigerator compartment.

- a. For coldest temperatures, slide control to left (ice crystals may form); for cold temperatures, slide control to right. See Figure 56.

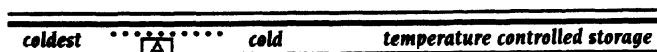

Figure 56

- b. Refrigerator compartment temperature may be affected by setting of Deli Fresh Chiller temperature control. Adjust Temp-Assure™ control as needed. See page 6.
- c. To reposition Deli Fresh Chiller, pull drawer three-quarters out of sleeve. See Figure 57.

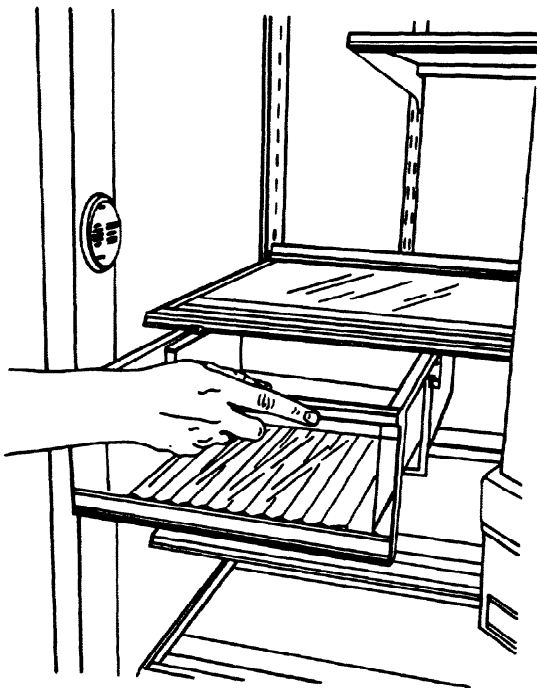

Figure 57

- d. Lift drawer up slightly to release from notches in grooves and pull drawer free. See Figure 58.

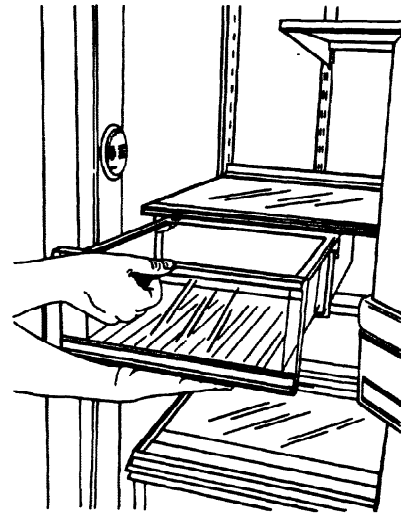

Figure 58

- e. To reposition Deli Fresh Chiller, loosen rear shelf hooks by tapping upward on rear of shelf near metal wall tracks.
- f. Lift shelf and Deli Fresh Chiller sleeve and pull out.
- g. Counting down from top slot of metal track on rear wall, use only slots 9, 10, 11, or 12 for new Deli Fresh Chiller position. Cold air supply tube **must** completely cover air inlet port on left rear refrigerator side wall. See Figure 59.

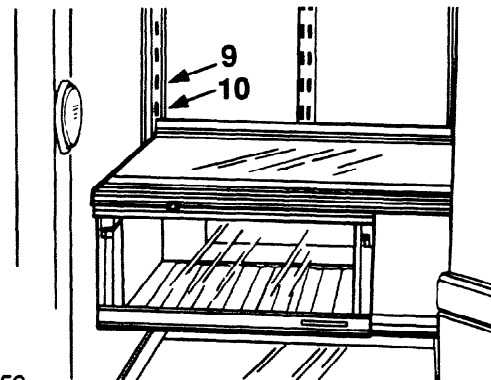

Figure 59

- h. Tilt up on front of shelf and sleeve, while inserting upper rear shelf hooks into desired slots on rear wall track.
- i. Gently lower front of shelf, while inserting lower shelf hooks into slots on rear wall track. Press down on hooks near wall track until shelf is level and hooks are securely seated.
- j. Replace Deli Fresh Chiller drawer.

Installing and Using Specific Features (continued)

Crispers

Store fresh fruits and vegetables in the crisper drawers. See Figure 60.

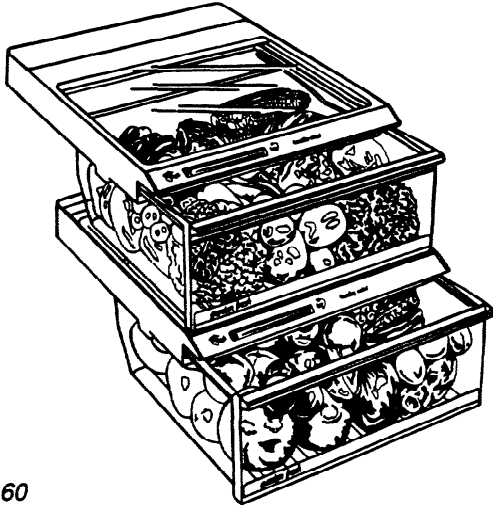

Figure 60

Normally, some moisture accumulates inside drawers. Humidity controls for one or both drawers are available on certain refrigerator models.

- a. For leafy vegetables such as lettuce, spinach or cabbage, slide control to HIGH humidity setting. See Figure 61.
- b. For fresh produce with skins such as apples, oranges or tomatoes, slide control to LOW humidity setting. See Figure 61.

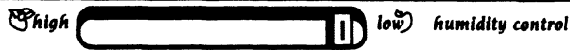

Figure 61

- c. Crisper drawers glide out full length on smooth rollers, even when door is open at 90° angle. To completely remove crisper drawers when door is opened 90°, remove two lower door shelves. See Figure 62.

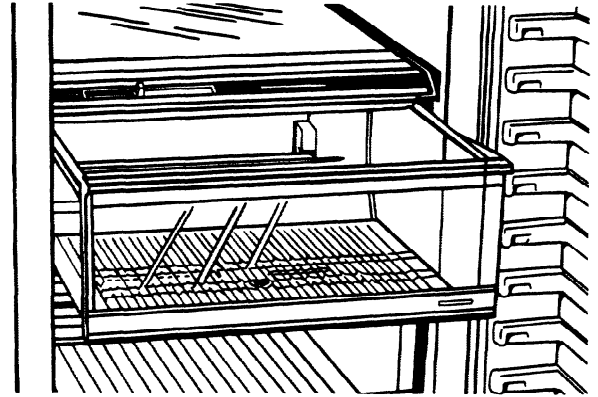

Figure 62

Installing and Using Specific Features (continued)

Freezer Features

Features vary from model to model. Your refrigerator may not have all features shown.

Starting with the freezer door, features are outlined from top to bottom of unit, and move from the door into the freezer compartment.

Removable Door Dike

(20 cu. ft. models only)

For kitchens with limited space, which restrict door opening to 90°, dikes snap out for removal of freezer basket and ice storage bin.

- Grasp door dike with both hands and firmly snap out.
- Replace door dike by aligning four push clips on dike with holes on freezer door. Push gently until dike snaps into place. See Figure 63.

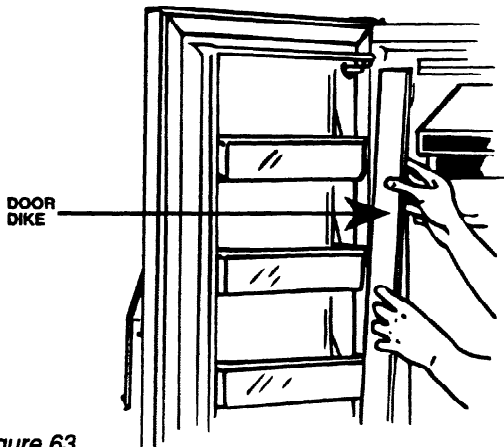

Figure 63

Door Shelves

Two styles of shelves on freezer door are removable for cleaning. One style can be moved up or down to fit storage needs.

- To remove non-adjustable hook-style shelves, gently tap upward underneath both ends. Lift and rotate bottom of shelf outward to release hooks from door slots. See Figure 64.

- To reinstall, tilt shelf and insert upper hooks into slots. Rotate shelf toward door and insert lower hooks into door slots.
- Hold shelf against door and tap down gently on both ends until shelf is seated securely. See Figure 64.

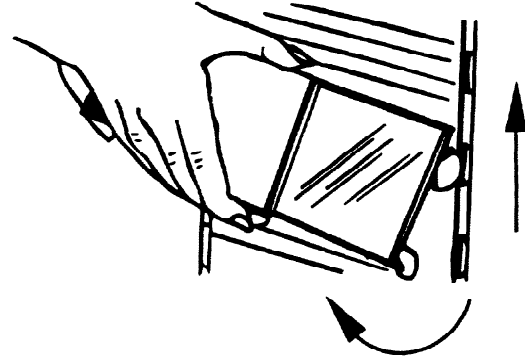

Figure 64

- To remove adjustable hook-style shelves, gently tap upward underneath both ends. Lift and rotate bottom of shelf outward to release hooks from door slots.
- To reinstall, tilt shelf and insert upper hooks into selected slots. Rotate shelf toward door and insert lower hooks into door slots.
- Hold shelf against door and tap down gently on both ends until shelf is seated securely. See Figure 65.

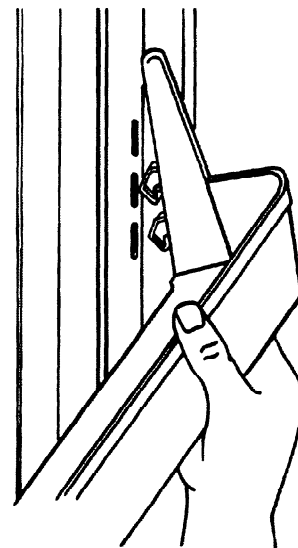

Figure 65

Installing and Using Specific Features (continued)

Adjustable Door Buckets

Storage buckets can be moved up or down.

- Remove all food from buckets.
- With thumbs and forefingers of both hands, push and hold lock tabs toward center of bucket. See Figure 66.

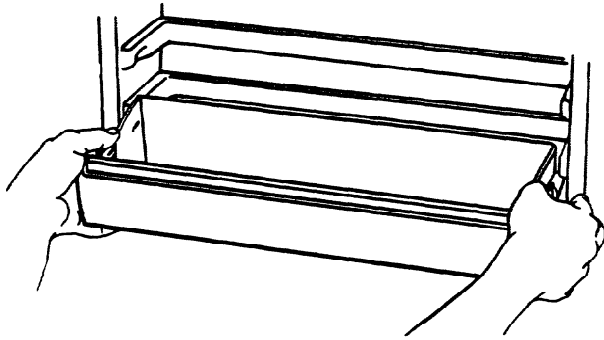

Figure 66

- Move bucket by holding lock tabs in and pulling bucket straight out. See Figure 67.

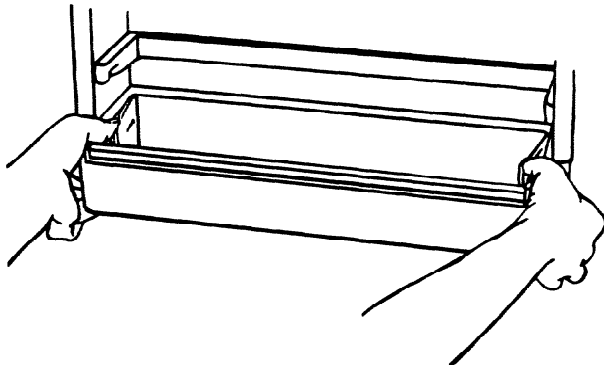

Figure 67

- To reinstall, use one hand at each side of bucket. Slide bucket into grooves on door. Push gently with thumbs until tabs snap and lock into place. See Figure 68.

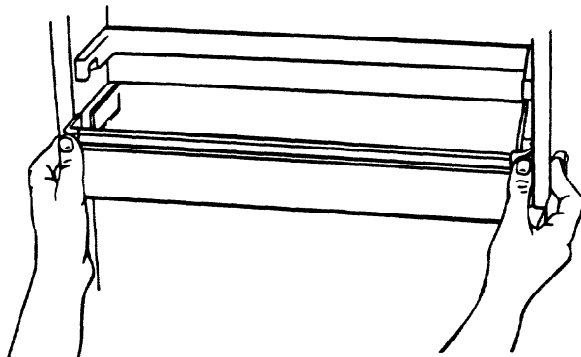

Figure 68

Tall Package Retainer

Retainers in door buckets of 20 and 27 cu. ft. models keep tall packages or containers in place. Tilt retainer inward, toward door, and lift up to remove. See Figure 69.

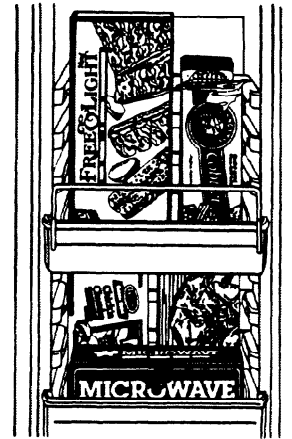

Figure 69

Retainer Bar

Retainer bar for shelf above ice dispenser chute keeps packages in place. See Figure 70.

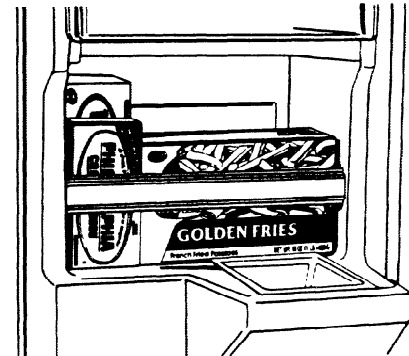

Figure 70

Remove bar by pulling to left or right. See Figure 71.

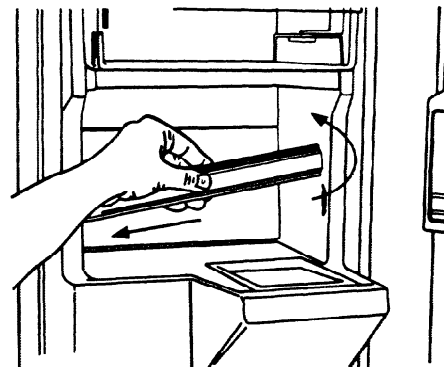

Figure 71

Installing and Using Specific Features (continued)

Adjustable Compartment Shelves

Supported by snap-lock tabs on right side wall of freezer, shelves adjust to fit storage needs.

- a. Remove shelf by gently pulling on right side wall snap-lock tabs to release. Lift right side of shelf. See Figure 72.

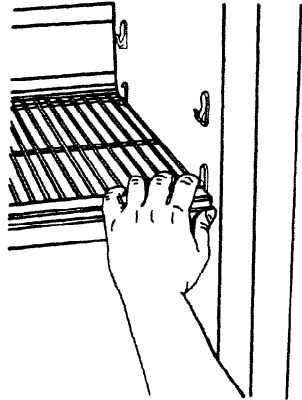

Figure 72

- b. Tilt shelf up and to left until shelf rods release from holes in left side wall. See Figure 73.

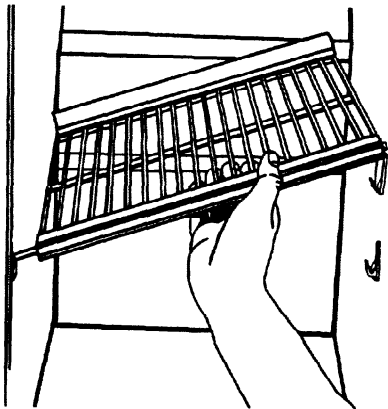

Figure 73

- c. Select desired shelf height. Insert shelf rods into holes in left freezer wall.
- d. Lower shelf onto snap-lock support tabs and press down until shelf is secure. See Figure 74.

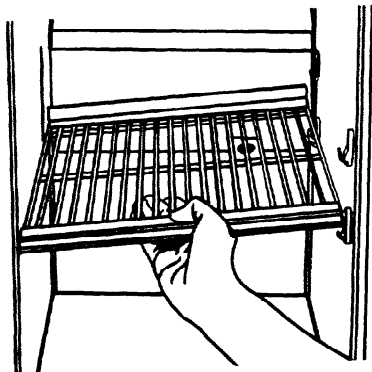

Figure 74

Glide-Out Wire Basket

Bulky, odd-shaped food items can be stored in a large wire freezer basket. See Figure 75.

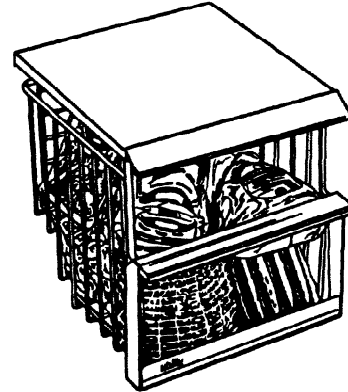

Figure 75

Ice Service Rack

A movable ice service rack, with flexible ice cube trays and a drawer for storing ice, is attached to the side of the freezer compartment. See Figure 76.

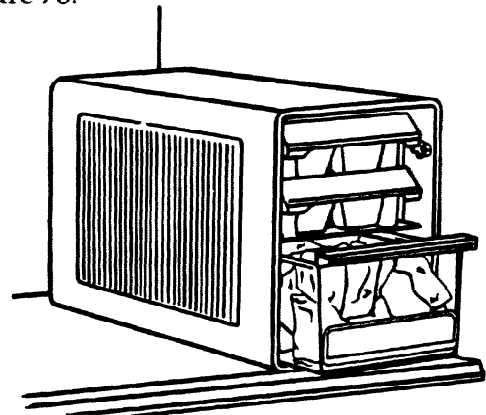

Figure 76

- a. To release ice cubes, grasp one end of tray in each hand. Hold it upside down above ice storage bucket.
- b. Twist ends of tray in opposite directions until cubes pop out. See Figure 77.

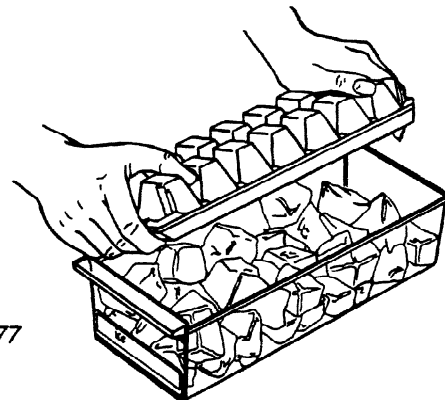

Figure 77

Installing and Using Specific Features (continued)

Ice 'N Water™ Dispenser

The Ice 'N Water™ Dispenser, a special feature of the Amana Side-by-Side Freezer Refrigerator, offers access to water and cubed or crushed ice at any time of day or night, while keeping doors closed.

- Refrigerator **must** be connected to household cold water service.
- Dispenser is interrupted when freezer door opens. Ice bucket may then be safely serviced.
- Spill shelf is **not** self-draining, so excess water should be poured into sink or wiped dry immediately. See Figure 78.

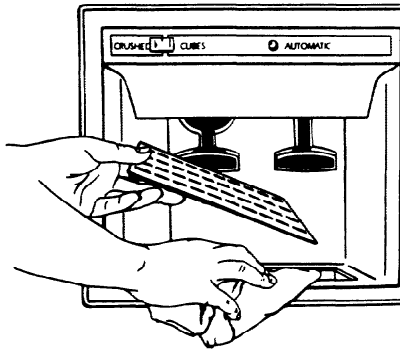

Figure 78



CAUTION

To avoid personal injury or property damage, freezer door **must** remain closed when operating dispenser.

Refrigerator **must** be unplugged and ice storage bin **must** be removed before attempting to service dispenser system.

Never put fingers, hands, or any foreign object into ice dispenser opening while attempting to manually clear stalls or jams.

Never use sharp objects to break ice.

Water Dispenser Operation

- Hold and press container against Water Dispenser bar to fill with water.

- Release pressure on bar to shut off water. See Figure 79. Slight dripping may occur. Spill shelf is **not** self-draining, so large spills should be wiped dry immediately. See Figure 78.

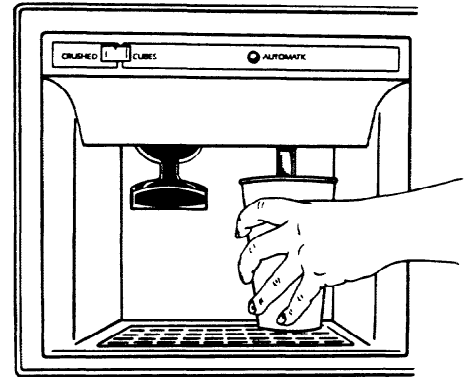

Figure 79

NOTE

First glass of water may be somewhat warmer than the following glasses, since water remains in unrefrigerated line to dispenser.

Cubed and Crushed Ice Dispenser Operation

(19 cu. ft. model dispenses only cubes.)

- Select CUBE or CRUSHED mode by sliding lever on front dispenser panel to chosen setting. See Figure 80.

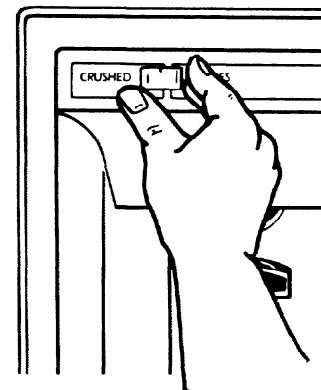

Figure 80

- Hold container close to chute and press container against Ice Dispenser bar to minimize spraying ice bits beyond container. Auger is activated and ice wheel automatically delivers cubed or crushed ice to container.
- Release pressure on bar **before** container is full, as some ice continues to fall. Do **not** remove container until the last of the ice falls.

Installing and Using Specific Features (continued)

CAUTION

To avoid property damage, do **not** dispense ice directly into thin glass, fine china or delicate crystal. Cracks or chips may result from ice dropping into container and from combined pressure of hands and dispenser bar.



- d. If Dispenser bar is held for long periods, as when filling large containers, dispenser motor shuts off automatically after 4 to 5 minutes to prevent overload. Motor resets automatically after 3 minutes and ice dispensing can continue.
- e. Normally, a slight delay occurs when switching between CUBE and CRUSHED ice modes, since time is needed for cubes to be moved from harvest bin.
- f. Pieces of crushed ice will vary in size and shape. Place container close to chute to minimize ice bits spraying beyond container.
- g. When repeatedly dispensing crushed ice, it is normal for a mound of snow to sometimes form on door and/or ice chute. Allow to evaporate or wipe moisture dry.
- h. Use **only** cubes from internal ice maker. Do **not** add purchased ice cubes or cubes made in any other manner, as unit operates only with cubes of proper size and shape.
- i. Allow 4 to 12 hours after installation before first harvest of ice. Time required depends on freezer temperature and amounts of food in freezer and refrigerator compartments.

IMPORTANT

Discard first few ice harvests after unit is installed to flush out water line impurities.

- j. To **temporarily** meet demand for increased ice production, turn freezer compartment control to colder setting. Return freezer compartment control to normal setting as soon as possible.

Dispenser

Automatic Night-Light

A control panel light turns on automatically when dispensing ice or water and when it becomes dark.

- a. To turn off night-light, push in on the front panel switch, located underneath shield and left of the ice dispenser bar.
- b. Regardless of the switch position, the light is activated when dispensing ice or water.

How the Water Dispenser Works

The Water Dispenser reservoir is located in the refrigerator behind the high-humidity compartment or crisper drawers, depending on the model, and water is routed to the Dispenser bar in a special way to prevent freezing.

- a. The water reservoir is covered with styrofoam or plastic, which **must not** be removed.
- b. When the Dispenser bar is activated, a solenoid in the water line is energized and water is added to the reservoir. Using the force of the household water pressure, water moves into the tubing and out through the Dispenser. See Figure 81.

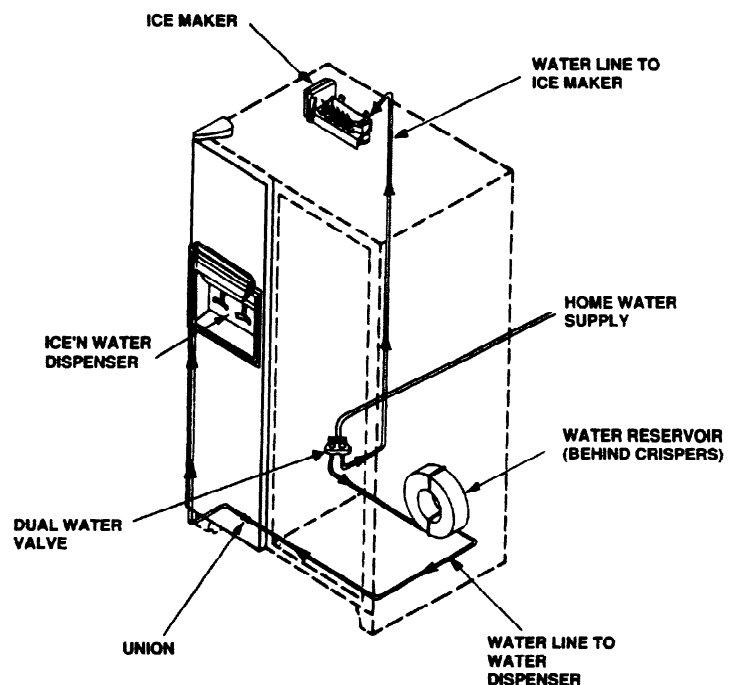

Figure 81

Installing and Using Specific Features (continued)

How the Ice Dispenser Works

For safety and for maximum freezer storage space, all mechanisms for ice making and dispensing are enclosed in a separate compartment.

- Water is automatically measured into the ice maker for freezing.
- Ice is produced when ice maker control arm is in the DOWN position. After the water freezes, a sensor activates the ejector blades to dump cubes into the U-shaped harvest bin for storage.
- When the Dispenser bar is pressed, the large auger moves ice from bin to Dispenser, providing ice cubes or crushed ice. (Cubes only provided in 19 cu. ft. model.)
See Figure 82.

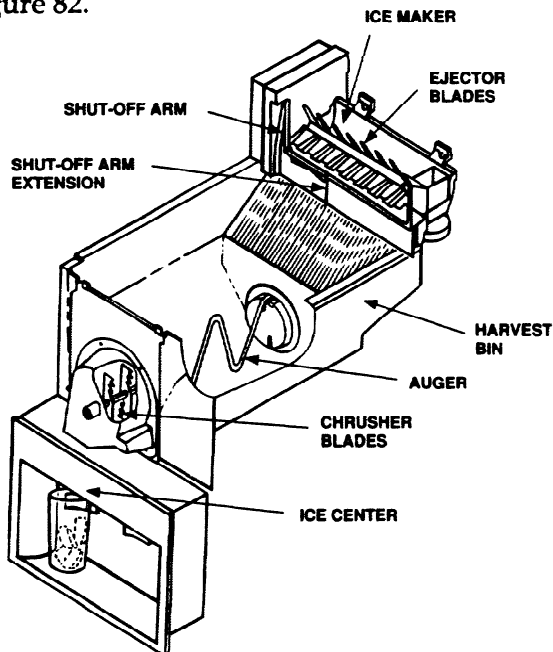

Figure 82

- In CUBE mode, auger turns ice wheel counter-clockwise to bypass crusher blades and move cubes directly to container.
- In CRUSHED mode, auger turns clockwise to force cubes into crusher blades and dispenses crushed ice directly to container.

IMPORTANT

Ice Maker is designed to produce from two (2) to four (4) pounds of ice in a 24-hour period, under ideal conditions of **room temperature, water inlet temperature and freezer compartment temperature**. If ice production is low, consider preceding items before assuming problem is ice maker. Ice production is noticeably affected by freezer compartment interior temperatures above +2°F (-17°C) and room temperatures above +75°F (+24°C).

Water Taste and Odor

Many variables affect the taste and odor of water, including:

- iron and other mineral deposits normally found in water.
- type of tubing used for household water supply and to connect refrigerator to household water.
- water left standing for long periods in the storage reservoir and/or water supply line.

Take the following recommended steps to ensure a fresh supply of water at all times and minimize taste and odor problems:

- Thoroughly flush the water dispenser system after initially connecting it to the household water supply by throwing away the first 10 to 14 eight-ounce glasses of water.
- After extended periods of non-use, flush the water system and reservoir as above.
- If problems persist, contact the local water treatment company for specialized help.
- Seal strong-smelling items in adequate moisture-vapor-proof material or airtight container.

Servicing the Ice Dispenser

Ice maker design allows basic self-servicing with minimum effort for the following situations.

- Clearing stalls or jams.
 - Removing ice bin and/or solid ice mass.
 - Stopping ice production.
 - Extended absences.
- To clear ice stalled or jammed in either CUBE or CRUSHED mode, try dispensing in opposite mode several times.



CAUTION

To avoid risk of personal injury or property damage, refrigerator **must** be unplugged and ice storage bin **must** be removed before attempting to service dispenser system.

Never put fingers, hands, or any foreign object into ice dispenser opening while attempting to manually clear stalls or jams.

Never use sharp objects to break ice.

Installing and Using Specific Features (continued)

If ice is used very little during the period of about a week, stored cubes may evaporate and freeze together in the ice storage bin or around ice auger, due to circulation of cold dry air needed in freezer compartment to maintain proper temperature.

b. To remove ice storage bin, raise ice maker shut-off arm to OFF position (audible “click” is heard). See Figure 83.

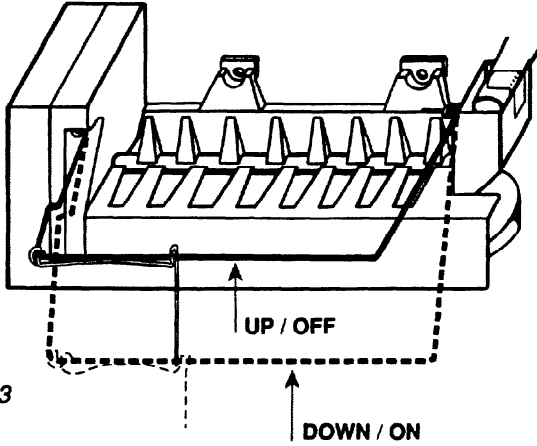

Figure 83

c. Lift up slightly on ice bin and pull out. Thaw/discard ice and return bin to freezer. See Figure 84.

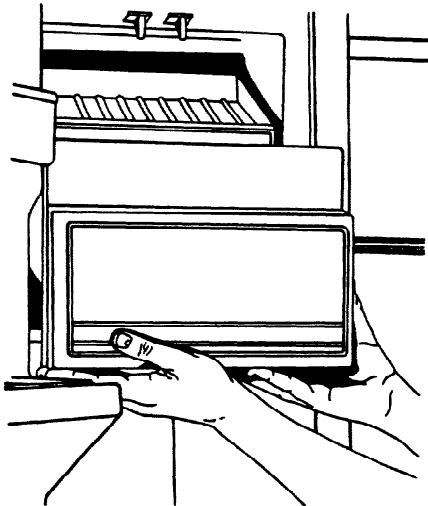

Figure 84

- d. To stop ice production, raise ice maker shut-off arm to OFF position (audible “click” is heard). See Figure 83. Remaining cubes will be dispensed from ice bin until all are used or until bin is emptied.
- e. When leaving for extended periods, raise ice maker shut-off arm to OFF position (audible “click” is heard). See Figure 83. Empty ice storage bin to prevent cubes from freezing around ice auger.

CAUTION
To avoid the risk of possible water damage, if the refrigerator will be unattended for long periods, shut off household water supply to refrigerator and raise ice maker shut-off arm to OFF position.

Other Features

Decorator Doors

Accent panels to complement kitchen decor can be used on most refrigerator and freezer door fronts when a Trim Kit is purchased separately from Amana dealers. Ask the Amana dealer about panel availability of special models. Panels are generally the owner’s responsibility. Amana **does not** supply custom panels.

- a. A basic 1/16” Trim Kit attaches to door edges, for 1/16” (1.6mm) panels.
- b. For 1/4” panels, an additional Adapter Trim Kit is required for 1/4” (6.4mm) panels to slide tongue-in-groove into the 1/16” Trim Kit, which must first be installed on doors.

Care and Cleaning



WARNING

To avoid electrical shock, personal injury or death, unplug refrigerator power cord or open household circuit breaker to refrigerator **before** replacing light bulbs or cleaning.

All removable refrigerator and freezer features should be cleaned regularly. Refer to appropriate section of *Installing and Using Specific Features* for removal and replacement instructions.

IMPORTANT

Avoid using the following materials or tools, which can cause surfaces to scratch, crack and discolor.

- concentrated liquid detergent
- abrasive heavy-duty cleaners or powders, such as COMET or AJAX
- metal or abrasive cleaning pads
- solvents

Adhesives

- To remove adhesive residue from items such as stickers, labels, or strapping tape, cover adhesive residue with non-abrasive toothpaste.
- Gently rub toothpaste over adhesive residue with fingers to remove. Wash cabinet surfaces with warm, soapy water. Rinse with clear water and dry thoroughly.

Exterior and Interior

- Use warm, soapy water to wash exterior and interior of refrigerator and freezer, as needed.
- Rinse surfaces with clear water and dry with soft cloth.

Door Gaskets

- Use mild detergent diluted in water to clean refrigerator and freezer door gaskets at least twice a year. Do **not** use cleaners containing ammonia or chlorine bleach.
- Rinse gaskets with clear water and dry with soft cloth.
- Apply a thin film of petroleum jelly to gaskets to help keep them soft and pliable.

Condenser Coil

Every three months, clean refrigerator condenser coil, located behind toe grille. Accumulated dust and lint reduce cooling performance, cause the refrigerator to waste energy, and shorten the life of the compressor and other components.

NOTE

Drain pan is removable for cleaning only on 20 cu. ft. models. Wash and dry drain pan before securely replacing in side supports, to protect from spills and rattling.

- Grasp toe grille at each end and pull forward to remove.
- On 19, 22, 25, 27 cu. ft. models, drain pan is **not** removable, but it can be cleaned.
- Use a long-handled bottle brush and a vacuum cleaner hose nozzle to remove dust and lint from condenser coil under refrigerator. (Amana dealers carry brush #R1930-4.)
- Replace toe grille by matching toe grille tabs with square holes in bottom of cabinet front.

Odor Removal

- Disconnect electrical power plug.
- Remove all food from freezer and refrigerator.
- Wash and dry all food containers.
- Wash compartment with mixture of 4 Tbsp. baking soda to one quart warm water.
- Wash all shelves, drawers, accessories, and gaskets, especially corners, crevices or grooves.
- Rinse compartment interior with clear water and dry all surfaces thoroughly with soft cloth.
- Returned cleaned containers and food to refrigerator and freezer compartments.
- Plug in refrigerator and set at normal operating temperature.
- In 24 hours, check to see if odor has been eliminated. If odor is still present, call the Amana toll-free Consumer Information Line at 1-800-843-0304 for additional cleaning methods.

Care and Cleaning (continued)

Light Bulbs



WARNING

To avoid electrical shock, personal injury or death, unplug refrigerator power cord or open household circuit breaker to refrigerator **before** replacing light bulbs.

Upper Refrigerator Compartment, Upper Freezer Compartment

(Non-Dispensing Models)

Replace bulbs with 40-watt appliance bulb, such as Amana #A0282803, GE or Westinghouse #40A15/1, or Sylvania #40A15. Light bulbs are located in upper front section of refrigerator and freezer compartments.

- Disconnect power to refrigerator and allow bulb(s) to cool.
- Remove bulb cover by pressing toward center on each rear corner to release from screws. See Figure 85.

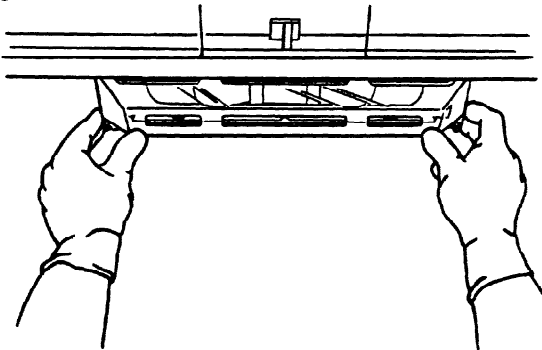

Figure 85

- Slide cover toward rear compartment wall to remove. See Figure 86.

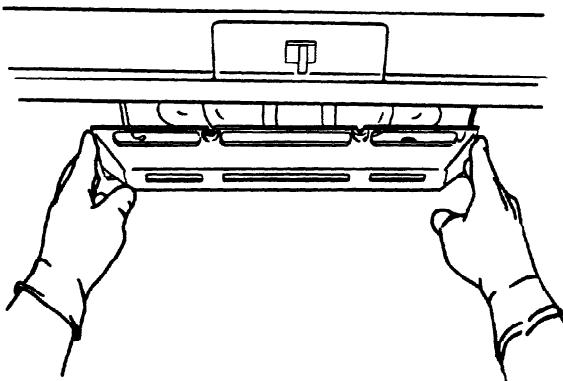

Figure 86

- Wear protective gloves to remove defective bulb(s) and replace with functioning bulb(s). See Figures 87 and 88.

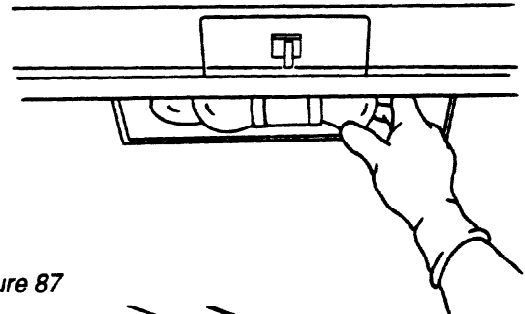

Figure 87

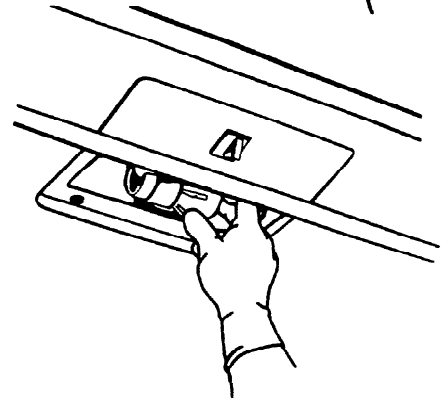

Figure 88

- Replace bulb cover.
- Reconnect power to refrigerator and set to normal operating temperature.

Lower Refrigerator Compartment

Replace bulb with 40-watt, intermediate base, tubular bulb, GE #40T6-1/2 /2 or Amana #A3079001. Light bulb is located on lower left side wall.

- Disconnect power to refrigerator and allow bulb to cool.
- Remove protective bulb shield by using a 1/4" driver or socket wrench. See Figure 89.

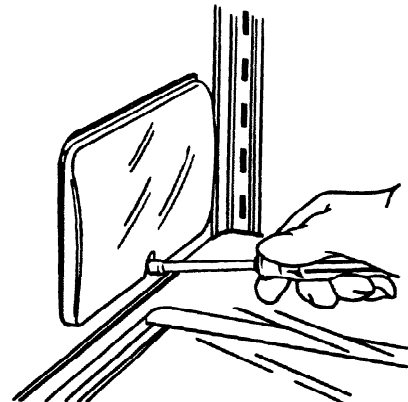

Figure 89

Care and Cleaning (continued)

- c. Wear protective gloves to remove defective bulb and replace with functioning bulb. See Figure 90.

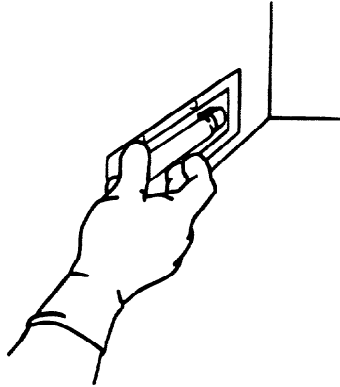

Figure 90

- d. Replace protective bulb shield, using a 1/4" drive or socket wrench.
- e. Reconnect power to refrigerator and set to normal operating temperature.

Freezer Compartment

(Dispenser Models)

Replace bulb with 40-watt appliance bulb, such as Amana #A0282803, GE or Westinghouse #40A15/1, or Sylvania #40A15. Light bulb is located on upper right wall, directly below ice maker dispenser bucket.

- a. Disconnect power to refrigerator and allow bulb to cool.
- b. Remove ice maker dispenser bucket.
- c. Remove protective bulb shield by using a 1/4" drive or socket wrench. See Figure 91.

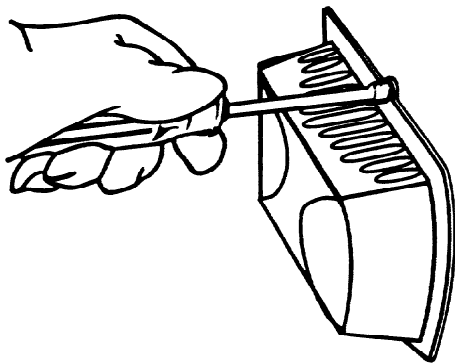

Figure 91

- d. Wear protective gloves to remove defective bulb and replace with functioning bulb. See Figure 92.

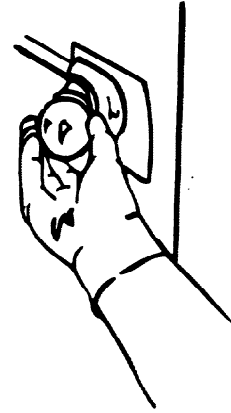

Figure 92

- e. Replace protective bulb shield, using a 1/4" drive or socket wrench.
- f. Reconnect power to refrigerator and set to normal operating temperature.

Ice 'N Water Dispenser

Replace bulb with 6-watt, 120-volt Sylvania #6S6 or Amana #M0360001. Light bulb is located between dispenser bars.

- a. Disconnect power to refrigerator and allow bulb to cool.
- b. Wear protective gloves to remove defective bulb and replace with functioning bulb. See Figure 93.

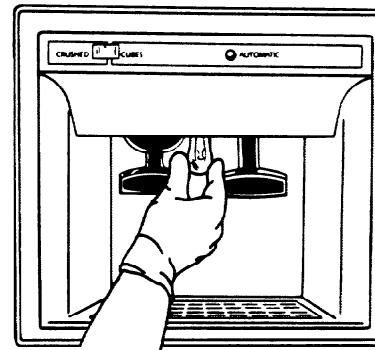

Figure 93

- c. Reconnect power to refrigerator and set to normal operating temperature.

Energy Tips

This Amana refrigerator is designed to be one of the most energy-efficient refrigerators available. Help reduce energy consumption by using the following suggestions.

- a. Set temperature controls for compartments and chillers so unit is not cooling more than necessary. See page 6 for details.
- b. Keep freezer section full to use less energy and to help maintain frozen temperatures when door is opened.
- c. Clean and lubricate door gaskets regularly. Gaskets seal doors and reduce leakage of cold air. Replace worn gaskets.
- d. Install refrigerator away from direct sunlight and block from heat sources.
- e. Clean condenser coil regularly. Dirty condenser increases energy use.

Vacation Tips

- a. Remove perishable foods from refrigerator.
- b. Shut off ice maker by moving wire "arm" to upper position.
- c. Turn off household water supply to refrigerator at saddle valve.
- d. When leaving for extended periods:
 - empty refrigerator completely;
 - unplug unit;
 - clean compartment interior;
 - prop compartment door open, so air can circulate inside; and
 - if ice maker is installed, turn off household water supply to refrigerator at saddle valve.

Non-Use Periods

Household Moves

- a. Unplug and clean unit.
- b. To prevent damage during shipment, use tape with non-permanent adhesive to secure all trays, shelves and other loose parts.
- c. Re-open unit as soon as possible after household move is complete.

Long-Term Storage

For storage in sub-freezing environment, take the following precautions to protect water valve.

- a. Disconnect refrigerator from power source.
- b. Turn off household water supply at saddle valve.
- c. Disconnect tubing from water valve couplings:
 - Remove lower rear cabinet cover.
 - Place a container under valve to catch water.
 - Remove brass tube fitting from valve coupling.
 - Label two plastic tubes attached to valve.
 - Unscrew compression nuts and push tubes away from valve fittings.
 - Use compressed air to remove all water from plastic tubing to water dispenser and ice maker.

Normal Operating Sounds of Today's Refrigerators

Today's refrigerators are designed for energy efficiency and economical operation. New features and designs may create sounds which are different than those of smaller or less efficient refrigerators. The sounds shown below are **normal operating sounds** and do **NOT** require

a service call. All of these sounds are normal and will soon become familiar. They indicate the unit is operating and performing as designed.

Features vary from model to model. Your refrigerator may not have all features shown.

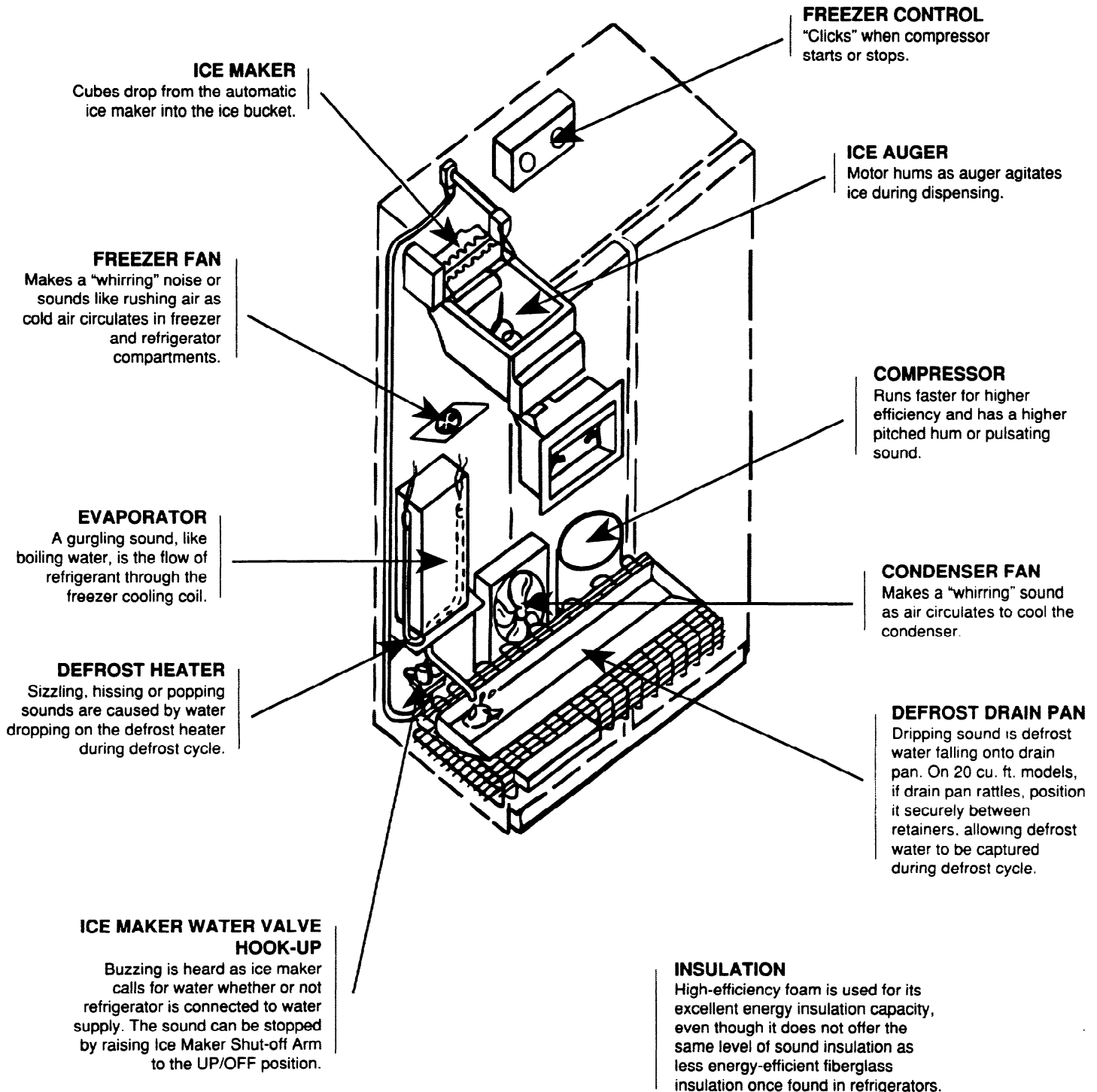

Before Calling For Service

Save the time and expense of a service call by checking for these common problems **before calling for service.**

<p>Refrigerator does not operate</p>	<ul style="list-style-type: none"> • Is the electric power cord plugged in? • Is a fuse or circuit breaker open? Check by plugging another appliance or lamp into the same wall outlet. • Do the interior lights work? A dim light indicates low voltage or a weak bulb. • If the lights work and the freezer control is on, but the two fans and compressor are not operating, the refrigerator is likely in the defrost cycle. Wait 30 minutes for refrigerator to restart. If it does not restart, remove the toe grille and locate the defrost timer. Turn the timer knob clockwise until it clicks and the compressor starts.
<p>If the refrigerator still won't operate</p>	<ul style="list-style-type: none"> • Take the necessary steps to preserve stored food. Dry ice may be placed in freezer compartment to preserve food until service is completed. Warranty does not cover food loss. • Unplug the refrigerator and keep doors closed until repair is complete. • If you have questions about the steps above, call Amana's toll-free Consumer Information Line at 1-800-843-0304. • Call the nearest Amana dealer or Authorized Service Center listed in the Yellow Pages.
<p>If food temperature appears too warm</p>	<ul style="list-style-type: none"> • Check the steps above to be sure refrigerator is operating properly. • Has a large amount of food recently been added? Allow adequate time for food to cool and to reach freezing temperature. • Are any wire shelves covered with foil or plastic, preventing proper air flow? • Is the condenser coil area clean? (See page 29.) • Adjust refrigerator and/or freezer temperature controls. (See page 6.) • Check refrigerator return air grille, to left of lower crisper at bottom of compartment, for adequate clearance.
<p>If the refrigerator or ice cubes have an odor</p>	<ul style="list-style-type: none"> • Clean the inside of the refrigerator and/or freezer. (See page 29.) • Use freezer containers or freezer wrap and cover all foods tightly. • Clean drain pan.

If the Deli Fresh Chiller is too warm

- Is Deli Fresh Chiller properly positioned, so air supply hole aligns with inlet tube on left side wall of refrigerator? (See page 20.)
- Slide Deli Fresh Chiller control to a colder setting.
- Adjust freezer control to a colder setting.

If the refrigerator food temperature is too cold

- Check that the Deli Fresh Chiller drawer is closed.
- Check Deli Fresh Chiller inlet tube connection. Inlet tube **must** cover air supply hole on left side wall of refrigerator. If not properly connected, freezer air spills into refrigerator section.
- Is condenser coil area clean? (See page 29.)
- Adjust refrigerator temperature control. (See page 6.)
- Adjust freezer control to warmer setting. Allow several hours for temperature to change.

If the refrigerator runs too much or too frequently

- It may be normal to maintain an even temperature.
- Have doors been opened frequently or for extended periods of time?
- Is condenser area clean? (See page 29.)
- Is freezer temperature set too cold? Adjust freezer control. (See page 6.)
- Check gasket seal and door alignment for proper closure.
- Has one-inch clearance at back and top of refrigerator been allowed for proper air exhaust? (19, 22, 25, 27 cu. ft. models)

If water droplets condense on inside of refrigerator

- This is normal during periods of high humidity or during heavy usage.

If water droplets condense on outside of refrigerator

- Check door gasket seal and door alignment for proper closure.

If there is water on the floor beneath the refrigerator

- Defrost drain pan (20 cu. ft. models only) may be missing or improperly positioned. (See page 29.)

<p>If the crisper or Deli Fresh Chiller drawers do not close freely</p>	<ul style="list-style-type: none"> • Check for a container which may be preventing proper closing. • Check that drawer is positioned properly within the assembly. • Clean drawer channels with warm, soapy water. • Apply a thin layer of petroleum jelly to channels for lubrication. • Check that refrigerator is level.
<p>If ice cubes stick together or 'shrink'</p>	<ul style="list-style-type: none"> • This is not a malfunction, but results from normal freezer air circulation, if cubes are used infrequently. • Empty ice cube bucket or ice trays more frequently.
<p>If ice forms in the water fill tube to the ice maker</p>	<ul style="list-style-type: none"> • Indicates sediment in the valve that keeps the valve from closing. • Add an in-line water filter. If problem persists, clean or change the water valve. • Check for adequate water pressure. Water pressure may drop if electrical power is out for extended periods or if power is supplied directly by a water pump. • Do not use self-piercing valve in water line. • Thaw by wrapping with very warm cloth.
<p>If cubed and crushed ice dispenser becomes jammed</p>	<ul style="list-style-type: none"> • Dispense in opposite mode. See page 27.
<p>If light bulbs need replacing</p>	<ul style="list-style-type: none"> • See instructions for changing bulbs on pages 30 and 31.

For questions regarding the information above, or for help in locating the nearest Authorized Amana Servicer, call Amana's toll-free Consumer Information Line at 1-800-843-0304.

Notes

Notes



Rest assured against unexpected repair bills!

EXTENDED SERVICE PLAN

Amana is pleased to offer longer-term service protection on your new Amana refrigerator. Supplementing Amana's strong refrigerator warranty, the Asure Extended Service Plan is specially designed to provide up to five full years of budget-protecting coverage for parts, labor and travel charges.

Your participating Amana dealer has details. Or contact us:

**Amana Refrigeration, Inc.
Consumer Affairs Department
Amana, Iowa 52204**

**Consumer Information Line
1-800-843-0304 (U.S.)
Monday through Friday Central Time
(normal business hours)**

